

ASSEMBLY INSTRUCTIONS











383-000035



IMPORTANT

PLEASE READ BEFORE YOU CONTINUE FURTHER

1. MATERIAL USE LAMINATED PARTICLE BOARD, TO CLEAN USE SOFT, DRY CLOTH.
2. DO NOT USE DETERGENT OR CHEMICAL AVOID CONTACT WITH WATER AND DIRECT SUNLIGHT.
3. TO BE ASSEMBLED ON A SOFT, DRY, CLEAN SMOOTH SURFACE.
4. DO NOT USE ANY TOOLS OTHER THAN THOSE SHOWN.
5. USE OF POWER TOOLS TO ASSEMBLE THIS PRODUCT WILL INVALIDATE ANY CLAIM AND MAY DAMAGE THIS PRODUCT MAKING IT UNSAFE.
6. BEFORE STARTING ASSEMBLY PLEASE VERIFY IF ALL PARTS AND HARDWARE ARE INCLUDED.

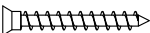
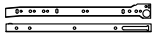
HARDWARE LIST			QTY (pcs)
DW4		Wood Dowel 6 x 25mm	24
HD6		Hande 128mm	2
LG1		Leg Pin	6
MF2		Nail	55 (+3)
MN2		Mini Fix 15mm	8 Sets
PF2		Single Plastic Cap	4
PF11		Small L Bracket	2
SC3		Screw M3.5 x 14mm	32
SC13		Screw M4 x 30mm	4
SC18		Screw M4 x 38mm	8
SC25		FH Screw M5 x 40mm	16
SL7		Drawer Metal Slide 350mm	2 Sets

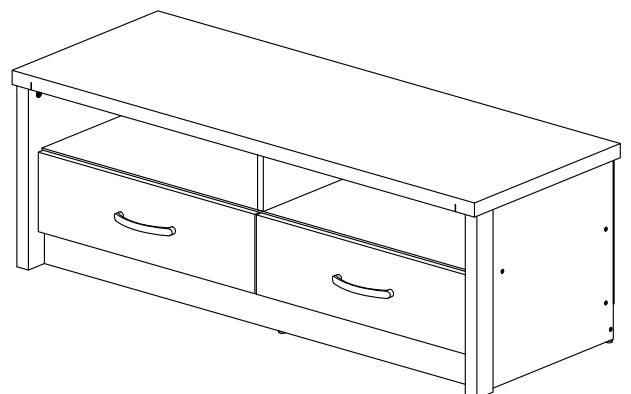



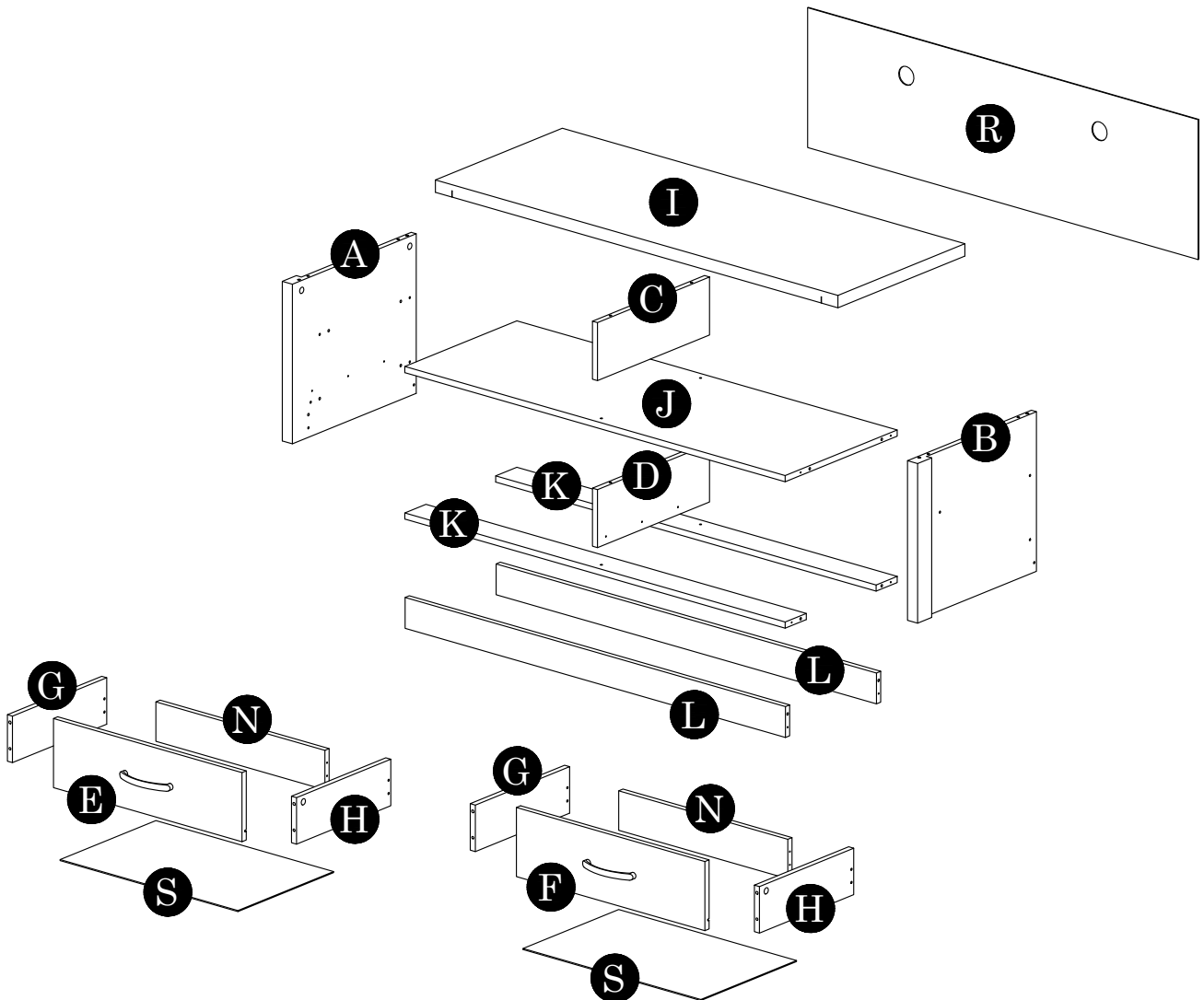

Parts List		QTY
A	Side Panel (L)	1 pc
B	Side Panel (R)	1 pc
C	Upper Center Panel	1 pc
D	Bottom Center Panel	1 pc
E	Drawer Front Panel (L)	1 pc
F	Drawer Front Panel (R)	1 pc
G	Drawer Side Panel (L)	2 pcs
H	Drawer Side Panel (R)	2 pcs
I	Top Panel	1 pc
J	Shelf Panel	1 pc
K	Big Crossbar	2 pcs
L	Bottom Crossbar	2 pcs
M	Side Crossbar	2 pcs
N	Drawer Back Board	2 pcs
O	Big Wood	2 pcs
P	Mid Wood	2 pcs
Q	Small Wood	1 pc
R	Backboard	1 pc
S	Drawer Bottom Panel	2 pcs

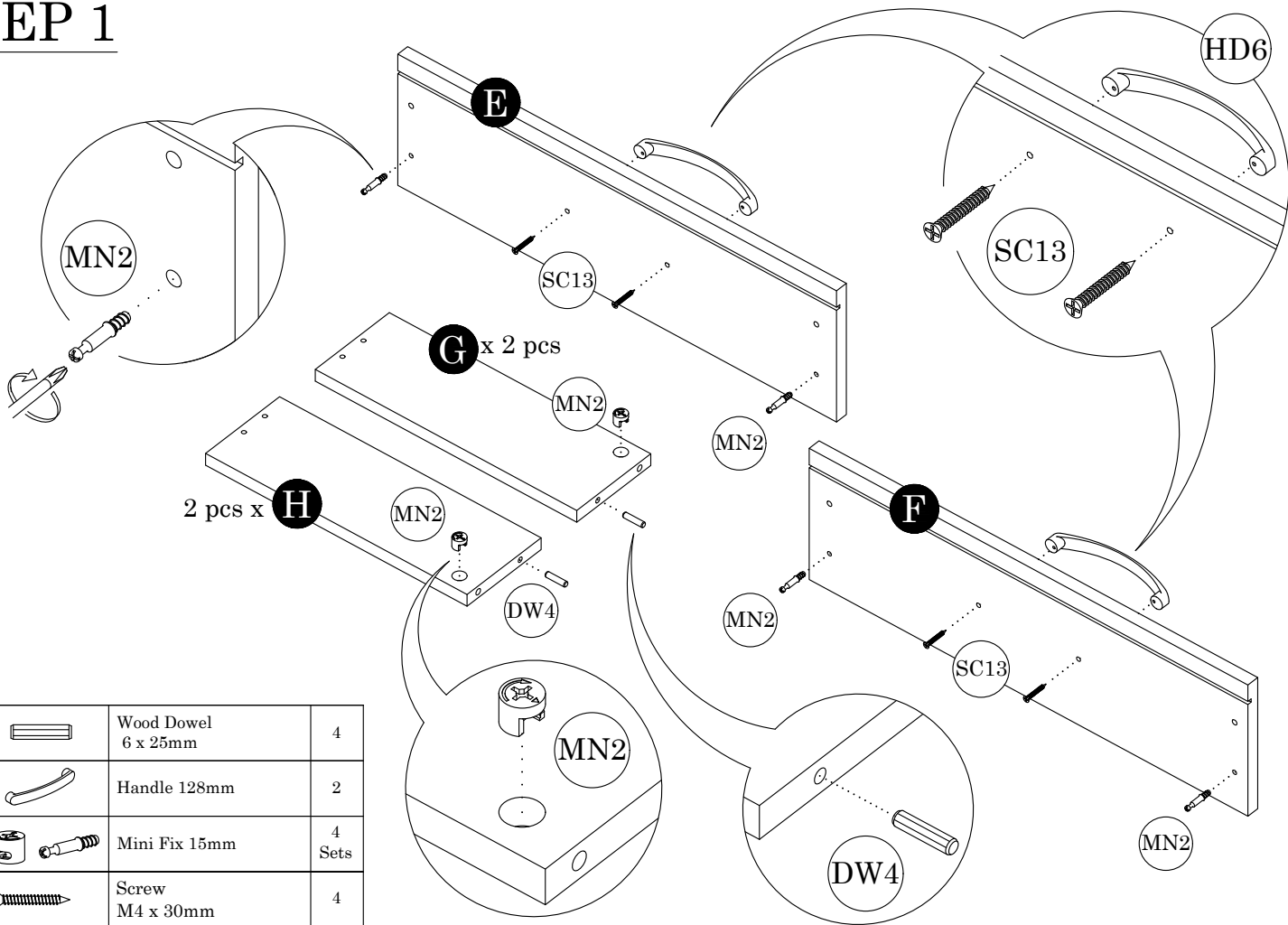



STEP 1



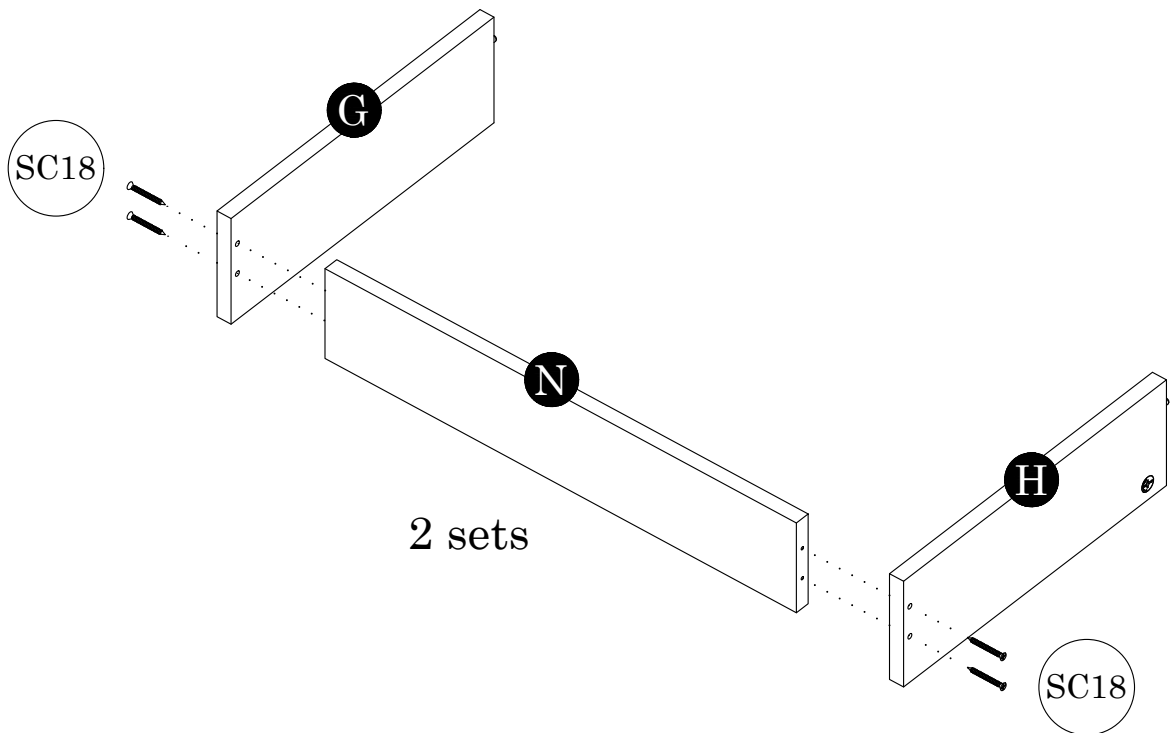

DW4		Wood Dowel 6 x 25mm	4
HD6		Handle 128mm	2
MN2		Mini Fix 15mm	4 Sets
SC13		Screw M4 x 30mm	4

STEP 2



SC18		Screw M4 x 38mm	8
------	---	--------------------	---

STEP 5

PF2		Single Plastic Cap	4
SC3		Screw M3.5mm x 14mm	16
SL7		Drawer Metal Slide 350mm	2 Sets

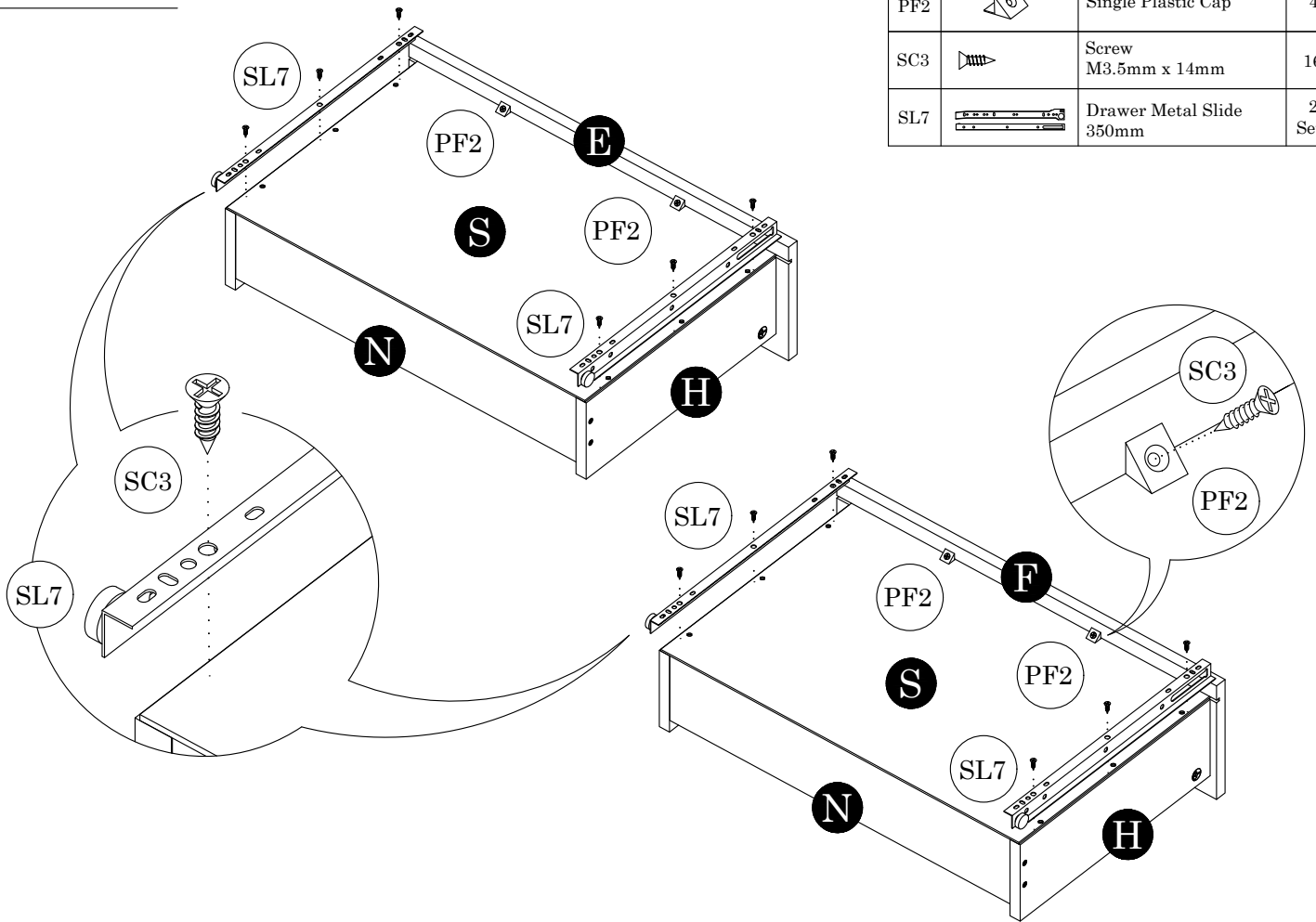

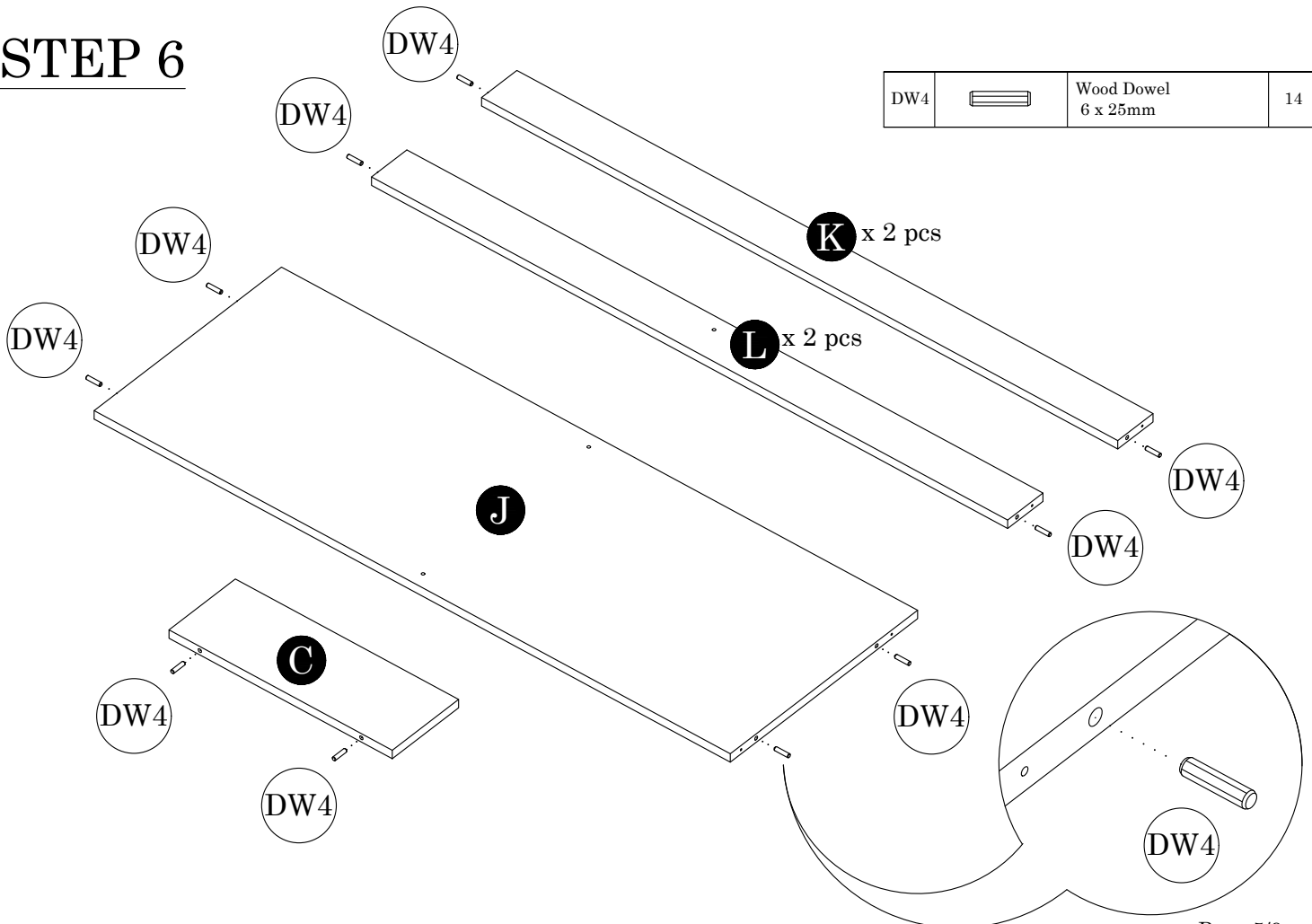

STEP 6

DW4		Wood Dowel 6 x 25mm	14
-----	---	------------------------	----

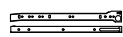

STEP 7

DW4		Wood Dowel 6 x 25mm	6
MN2		Mini Fix 15mm (Cam)	4
SC3		Screw M3.5mm x 14mm	12
SL7		Drawer Metal Slide 350mm	2 Sets

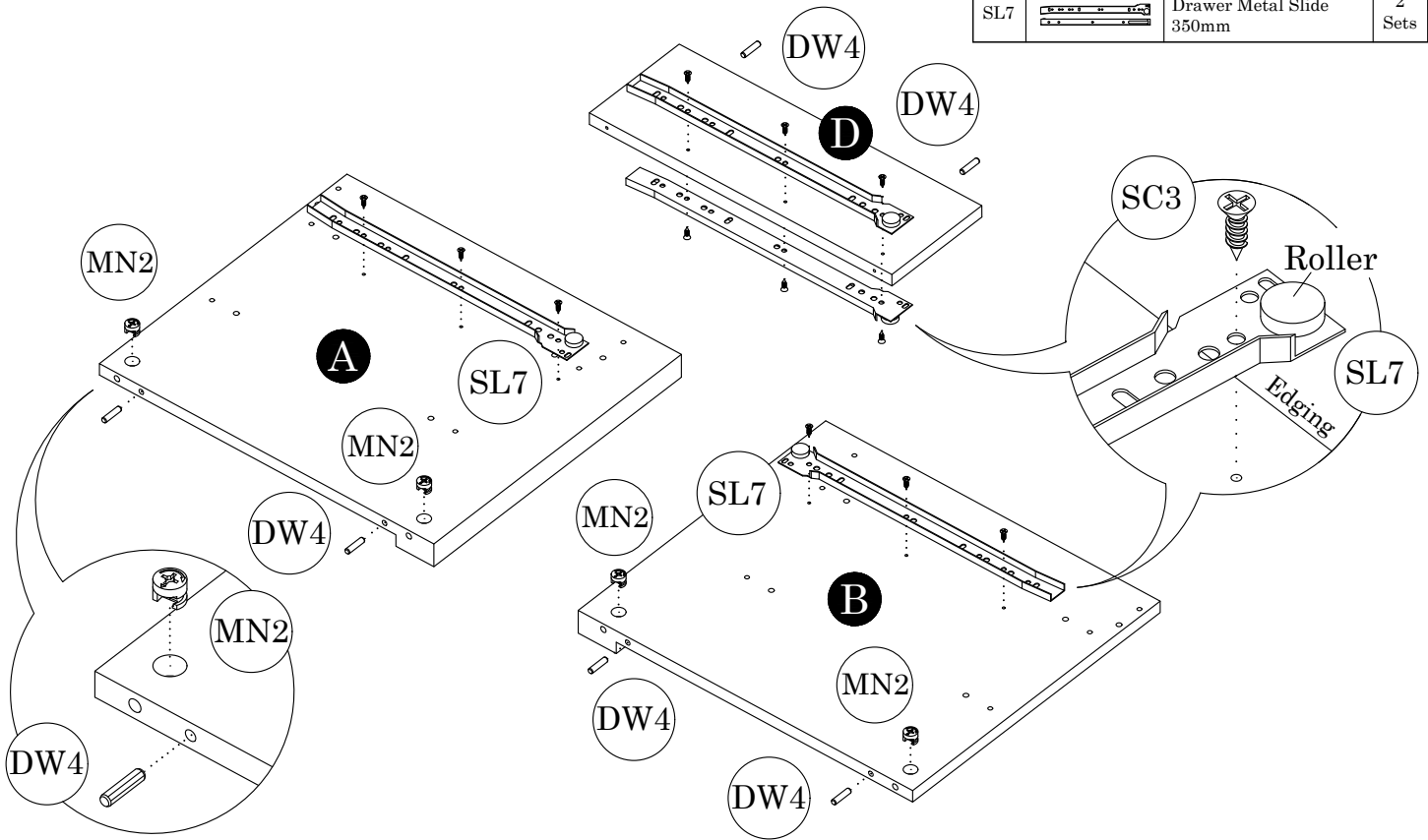

STEP 8

MN2		Mini Fix 15mm (Bolt)	4
-----	---	----------------------	---

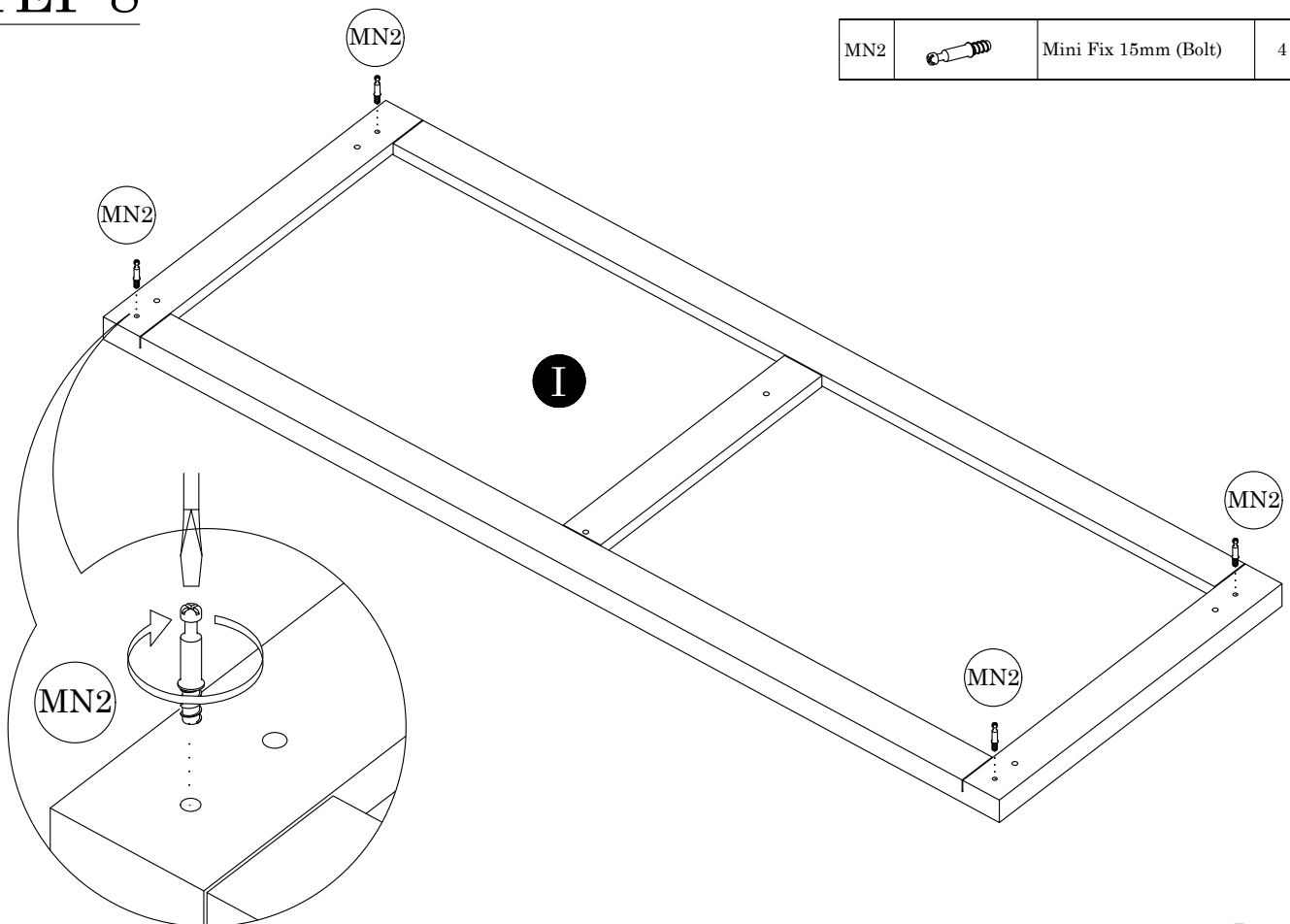

STEP 9

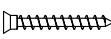
SC25		FH Screw M5 x 40mm	2
------	---	-----------------------	---

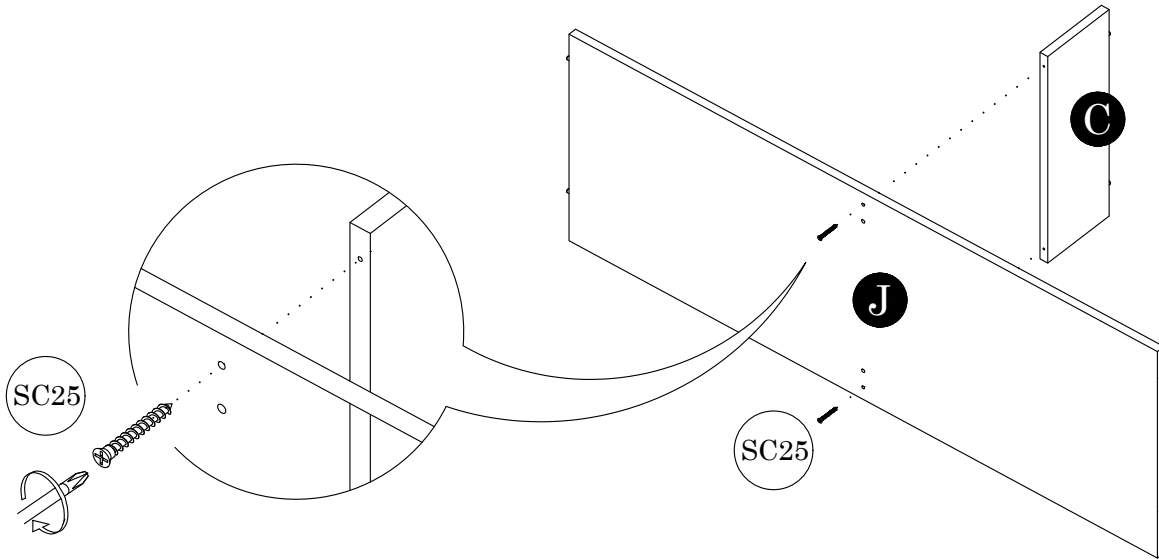

STEP 10

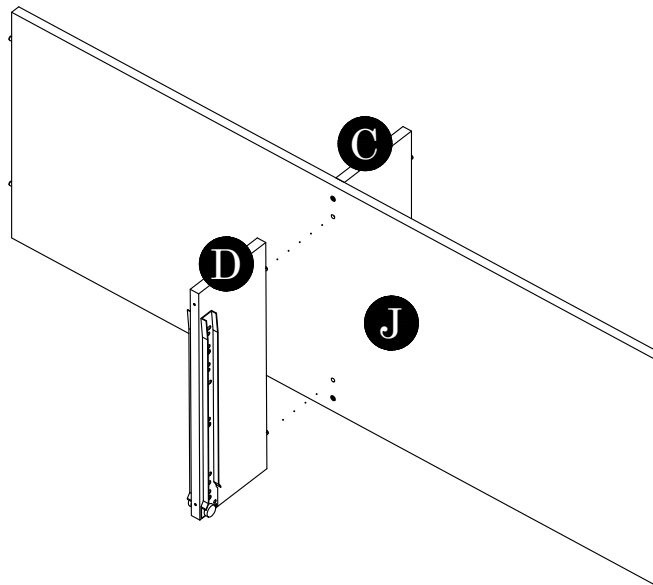

STEP 11

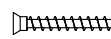
SC25		FH Screw M5 x 40mm	2
------	---	-----------------------	---

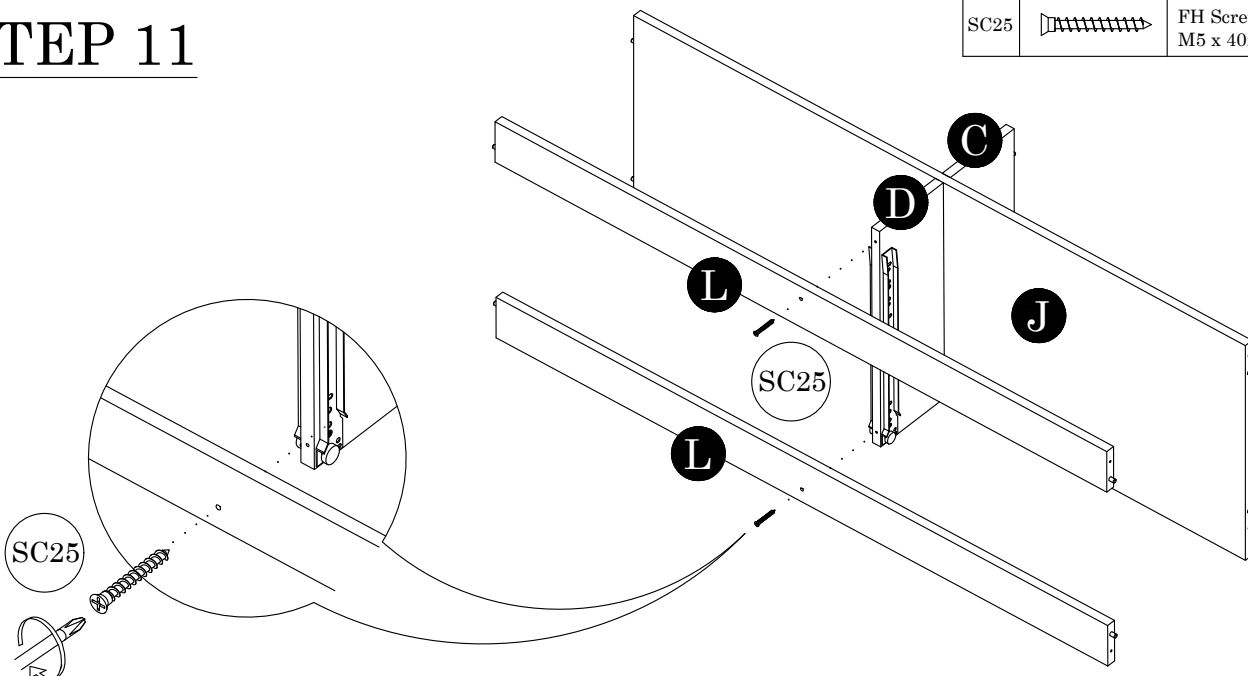

STEP 12

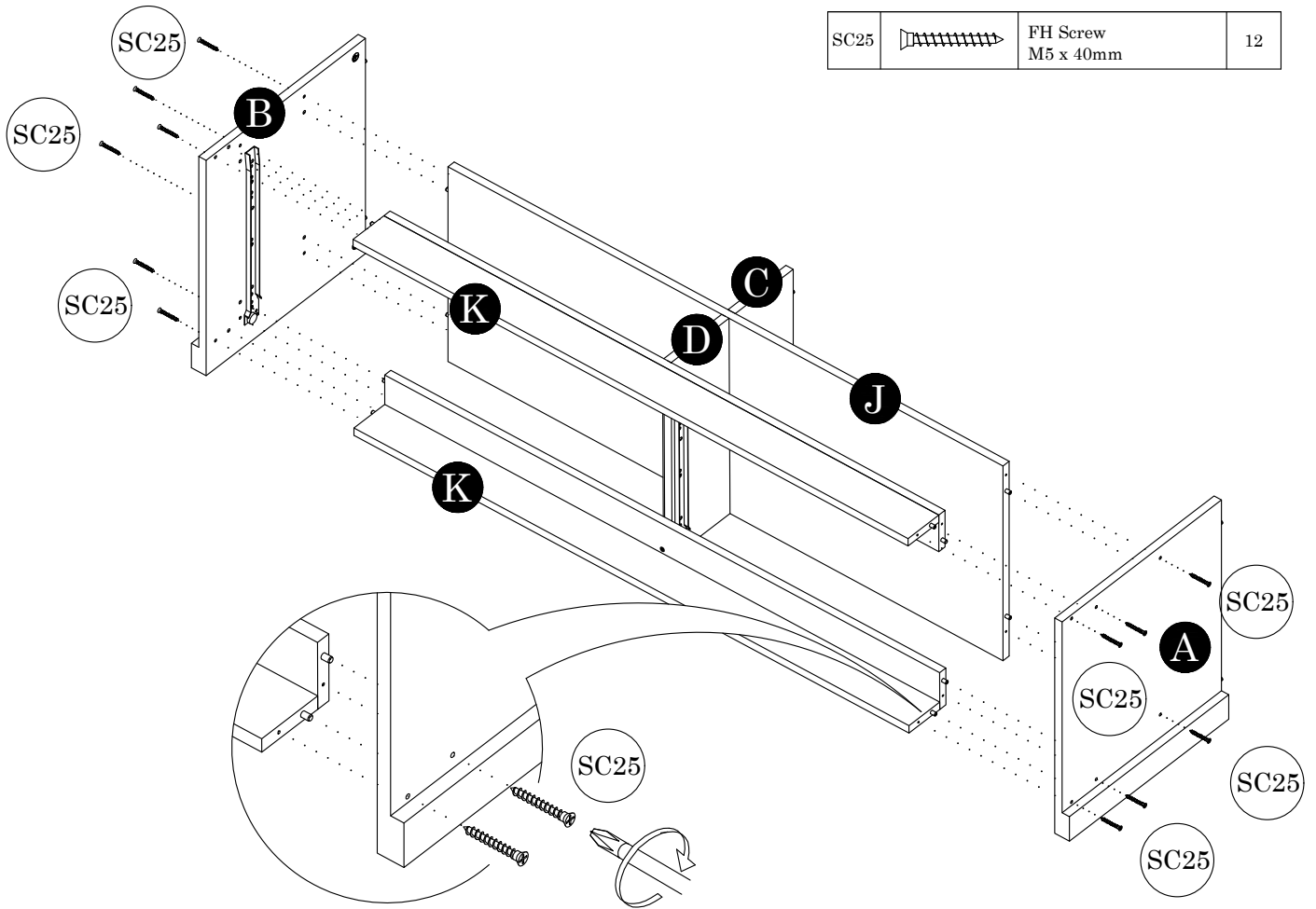

STEP 13

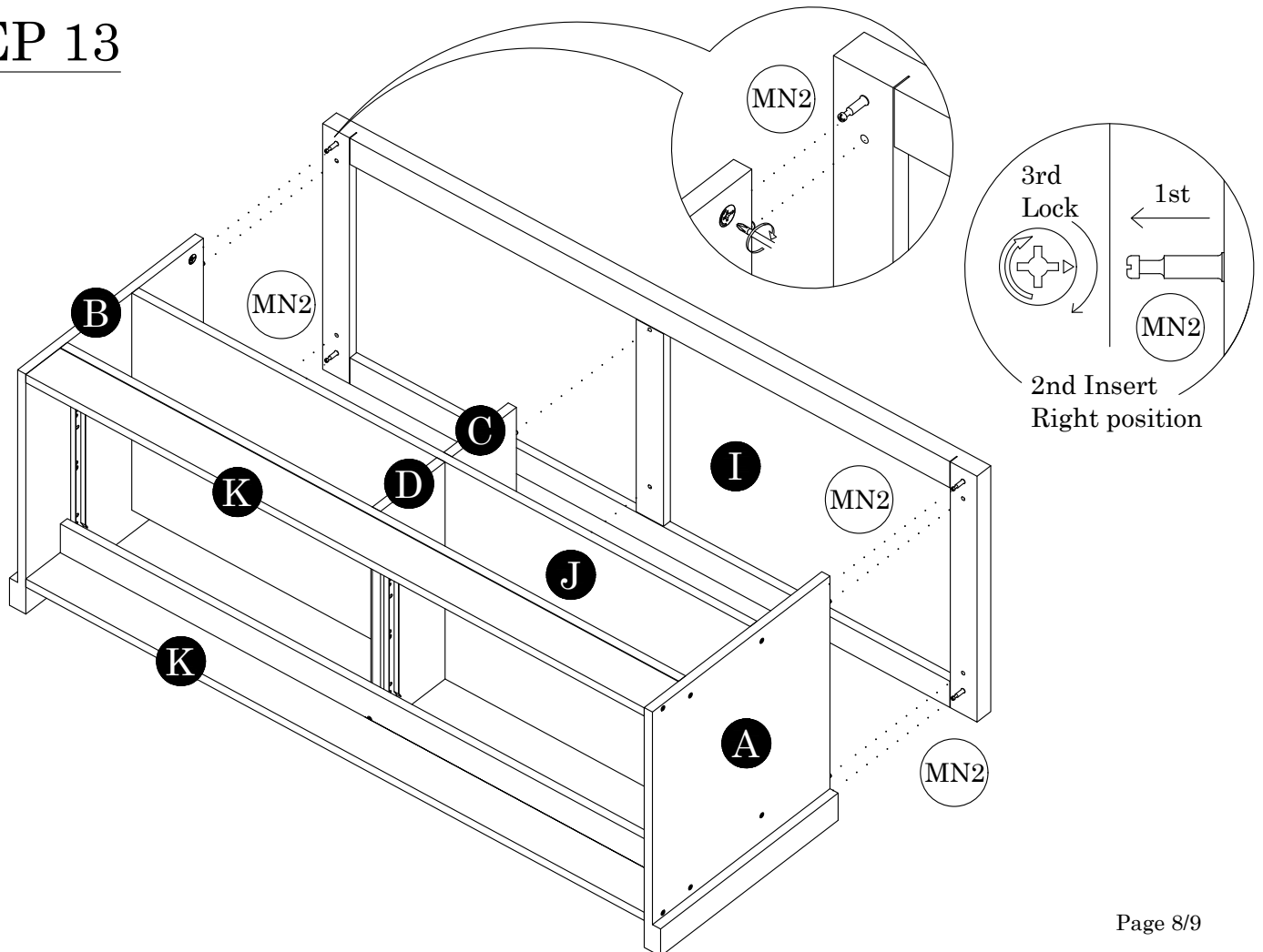

STEP 14

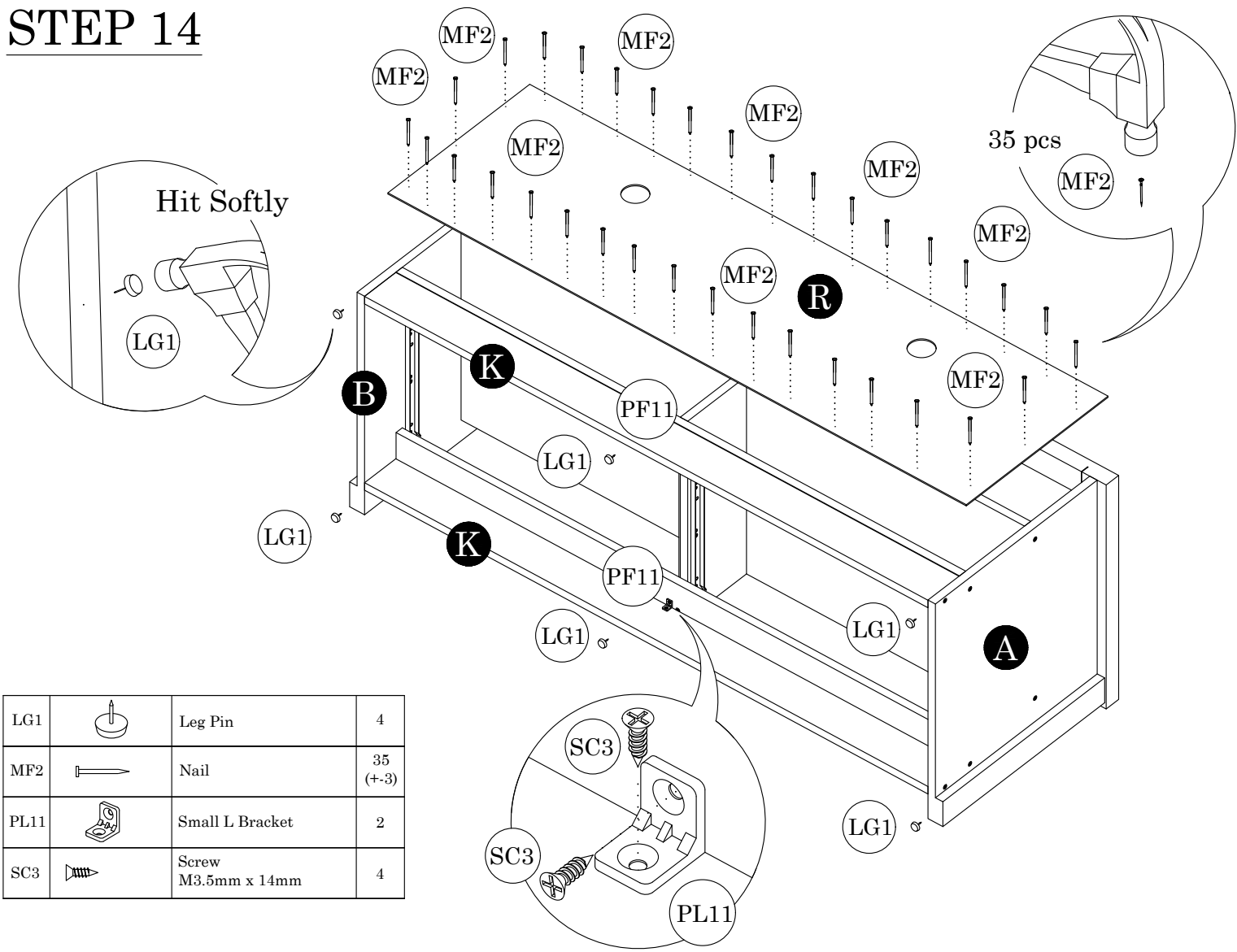

LG1		Leg Pin	4
MF2		Nail	35 (+-3)
PL11		Small L Bracket	2
SC3		Screw M3.5mm x 14mm	4

STEP 15

