













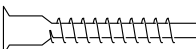

<p>A2 x 68_{pcs}</p>  <p>M3.5 x 14 mm</p>	<p>H6 x 4_{pcs}</p>  <p>128 mm</p>
<p>A6 x 4_{pcs}</p>  <p>M4 x 25 mm</p>	<p>L10 x 4_{pcs}</p>  <p>25 mm</p>
<p>A7 x 8_{pcs}</p>  <p>M4 x 30 mm</p>	<p>N1 x 1_{pcs}</p> 
<p>A17 x 8_{pcs}</p>  <p>M6.3 x 40 mm</p>	<p>N3 x 20_{pcs (+-3)}</p> 
<p>D7 x 4_{pcs}</p>  <p>8 x 40 mm</p>	<p>Q4 x 12_{pcs}</p> 
<p>E7 x 8_{pcs}</p>  <p>35mm 2/8"</p>	<p>R2 x 20_{pcs}</p> 
<p>F2 x 18_{sets}</p>  <p>15 mm</p>	<p>Y x 4_{pcs}</p> 

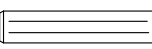
COMPLETE

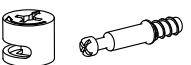

CAUTION

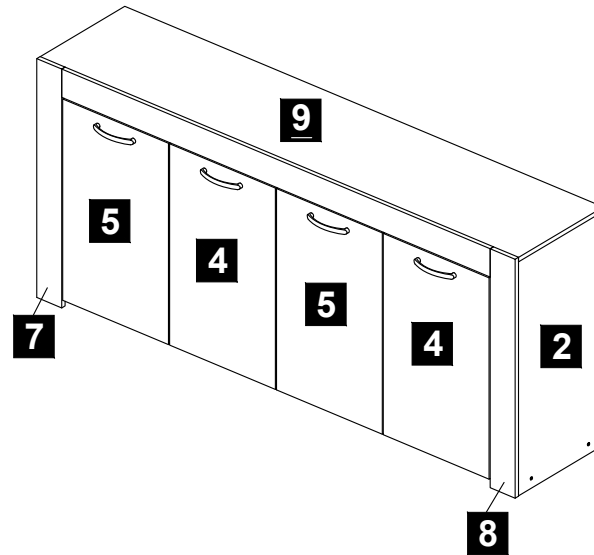
MATERIAL USE LAMINATED PARTICLE BOARD, TO CLEAN USE SOFT, DRY CLOTH. DO NOT USE DETERGENT OR CHEMICAL AVOID CONTACT WITH WATER AND DIRECT SUNLIGHT. TO BE ASSEMBLED ON A SOFT, DRY, CLEAN SMOOTH SURFACE.

USE OF POWER TOOLS TO ASSEMBLE THIS PRODUCT WILL INVALIDATE ANY CLAIM AND MAY DAMAGE THIS PRODUCT MAKING IT UNSAFE.



PRE - ASSEMBLY

STEP 1

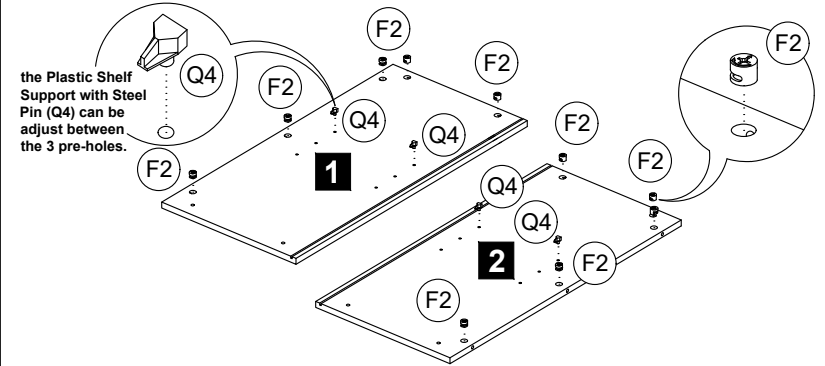

STEP 2

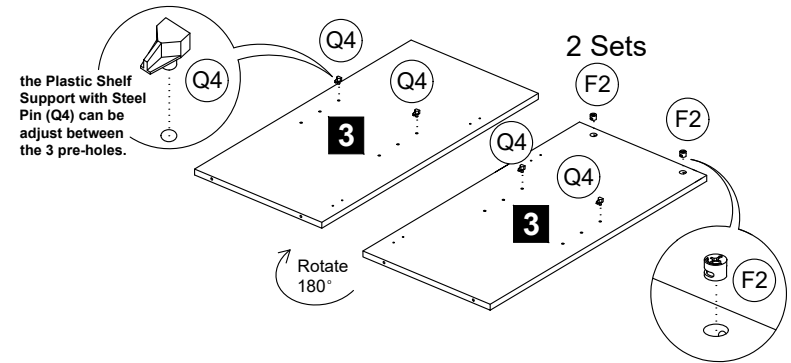

STEP 3

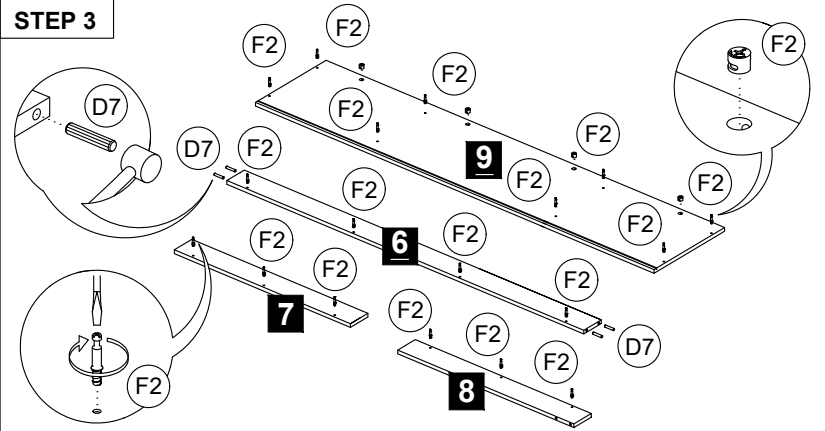

STEP 4

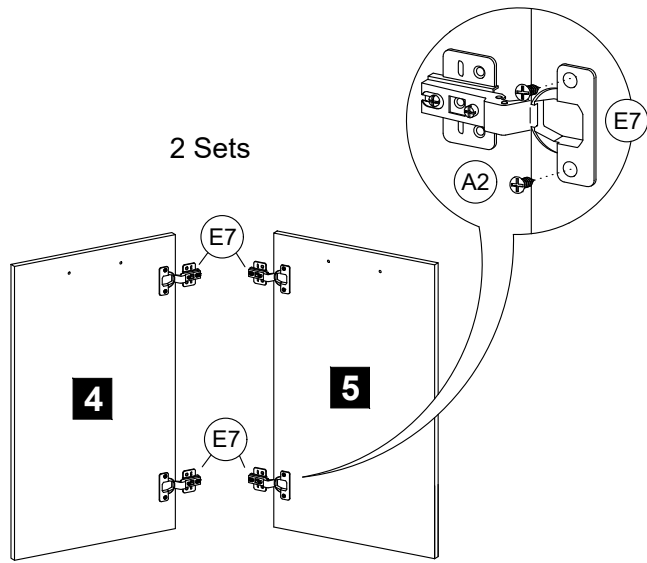

STEP 5

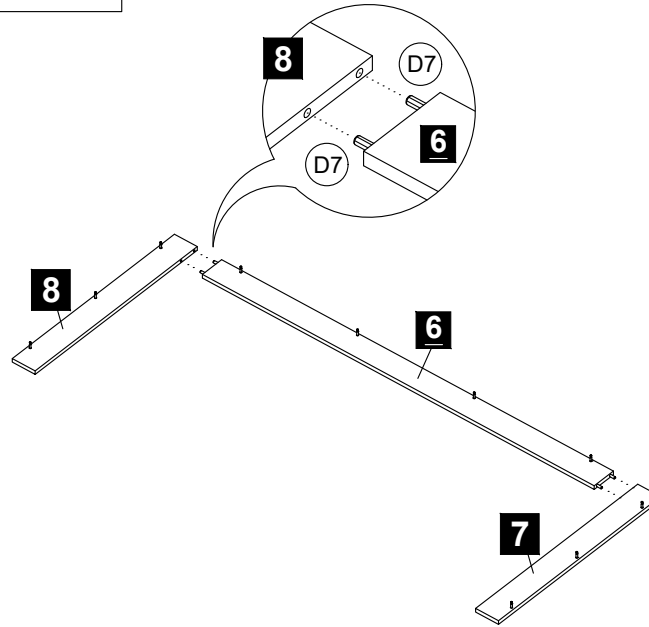

STEP 6

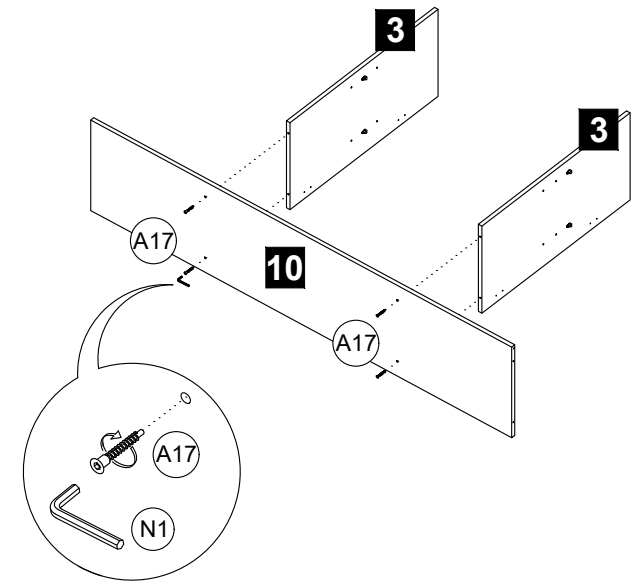

STEP 7

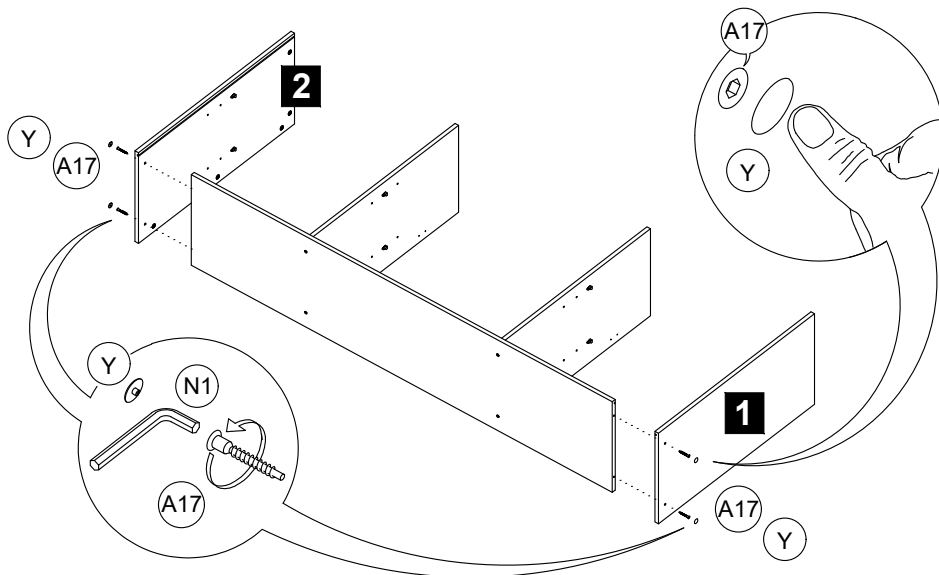

STEP 8

