

Before starting the assembly need to

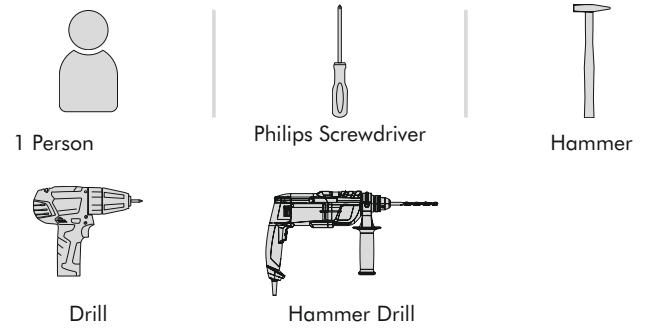

Dear Customer

This product you have purchased has been subjected to all tests and controls by us before it reaches you. However, your product may have been damaged during transport or shipped incompletely. Therefore, it is useful to check the current product using the manual before starting the installation. If you encounter a missing or faulty object during the check, define the object using the manual and contact our company. Our office will provide you with the object you need as soon as possible. You do not need to return the faulty product to our company.

For a successful installation, please provide the auxiliary tools mentioned above.

Before you start, clean every existing item with a damp cloth.

After cleaning the existing parts, arrange them in a suitable area according to the size. Meanwhile, be careful not to rub against each other while moving the pieces and not to hit the corner parts while arranging them.

During installation, carefully review all steps in the manual.

After the installation process is completed, check the integrity of all connection points.

After the assembly, carry the product as 2 people.











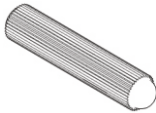









Do not expose your product to direct sunlight. Keep away from hot and humid environments. Position your product appropriately considering these issues. In addition, do not load the product with heavy loads that may cause stretching and do not use it outside of its purpose.

You can contact our company about the topics you are curious about.

ASSEMBLY

LIST OF PART

LIST OF ACCESSORIES

Code	Dimension	Pieces	LIST OF ACCESSORIES		
1	600 x 350 x 18	1	 x32	 x8	 x8
2	562 x 350 x 18	1	A01	A02	A03
3	350 x 228 x 18	1	 x26	 x10	 x20
4	350 x 228 x 18	1		A06 3,5x18	A08 4x50
5	600 x 246 x 18	1	 x2	 x1	 x1
6	554 x 89 x 18	2	A11	A17 5x70	A18
7	500 x 60 x 18	2	 x2	 x1	 x8
8	300 x 60 x 18	2	A25	A27	A41
9	300 x 60 x 18	2	 x16	 x2	 x4
10	532 x 303 x 3	2	 x16	 x2	 x4
11	450 x 450 x 18	1	A64 4x20	A78	A93
12	281 x 60 x 18	4	 x4	A98	

ASSEMBLY

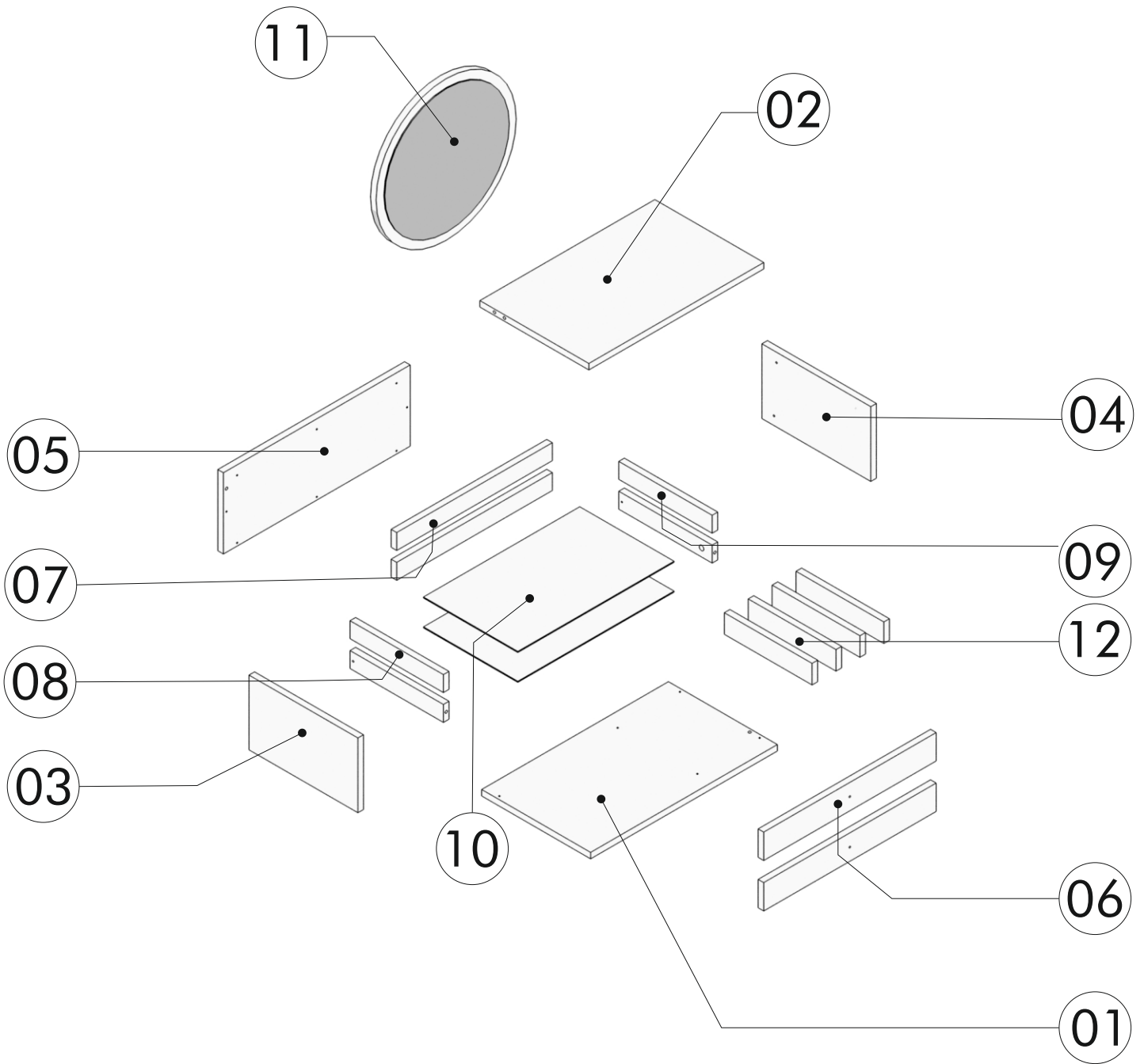

ASSEMBLY

01

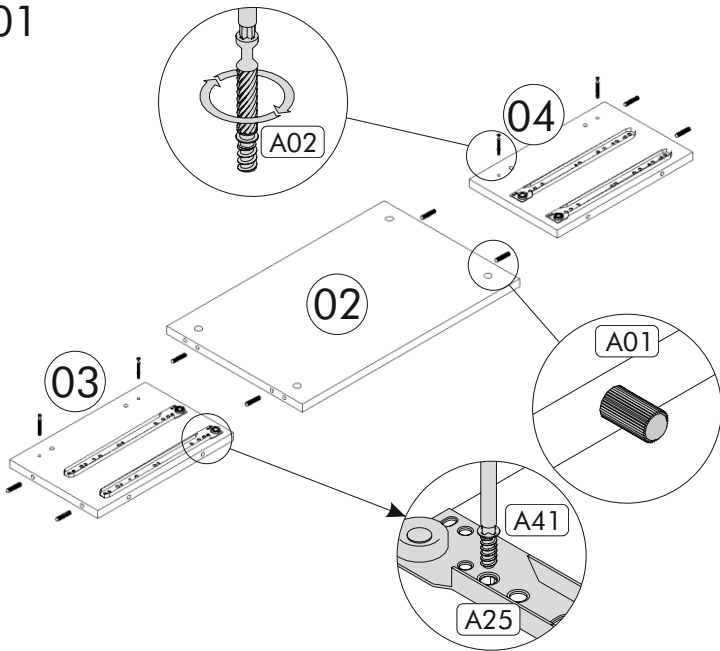

02

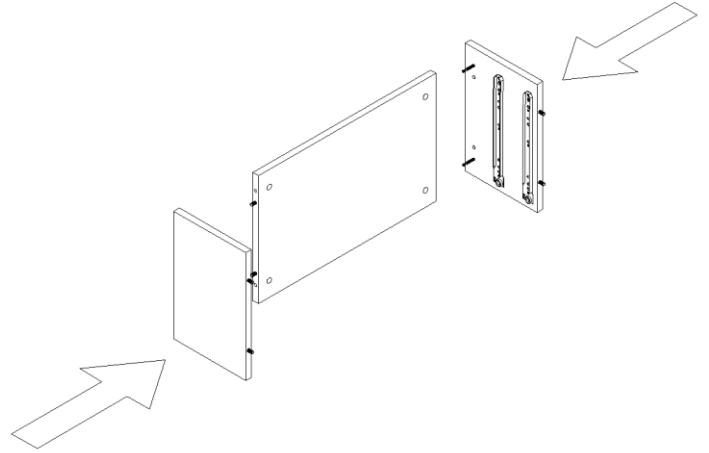

03

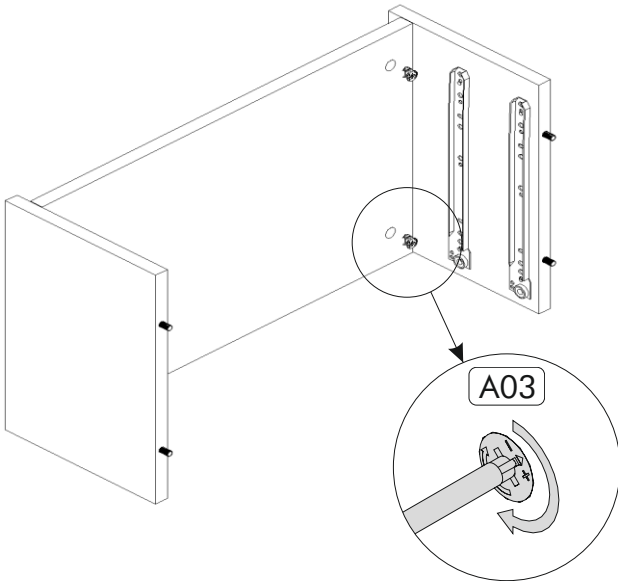

04

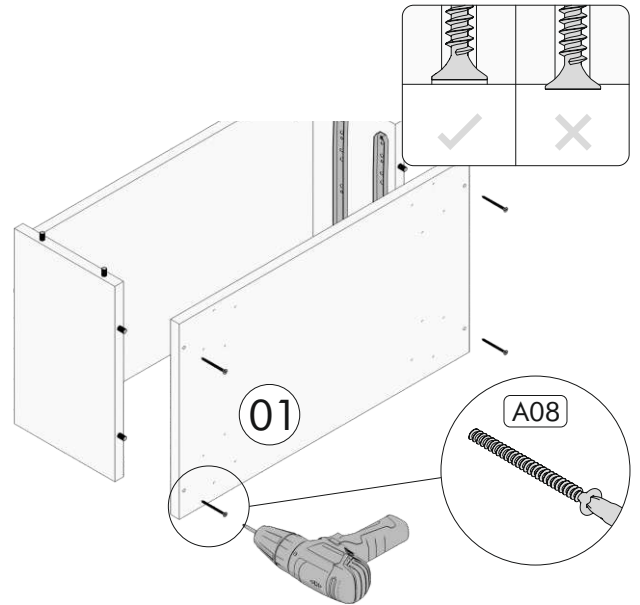

05

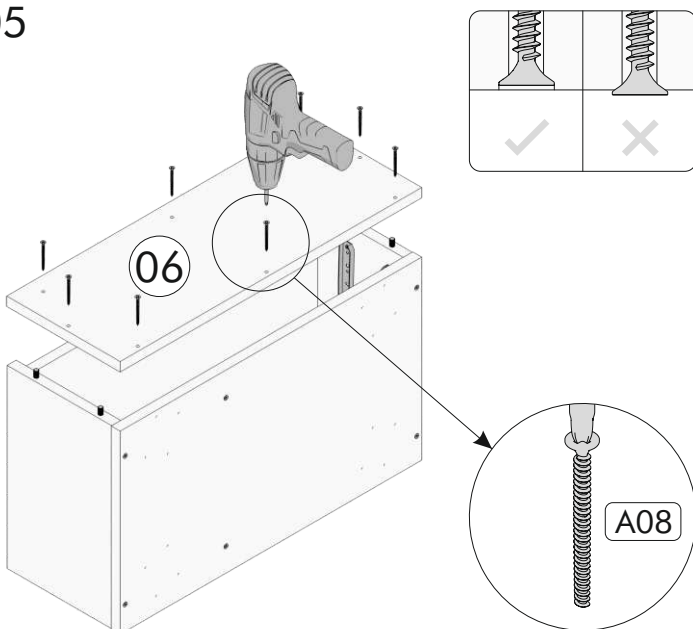

06

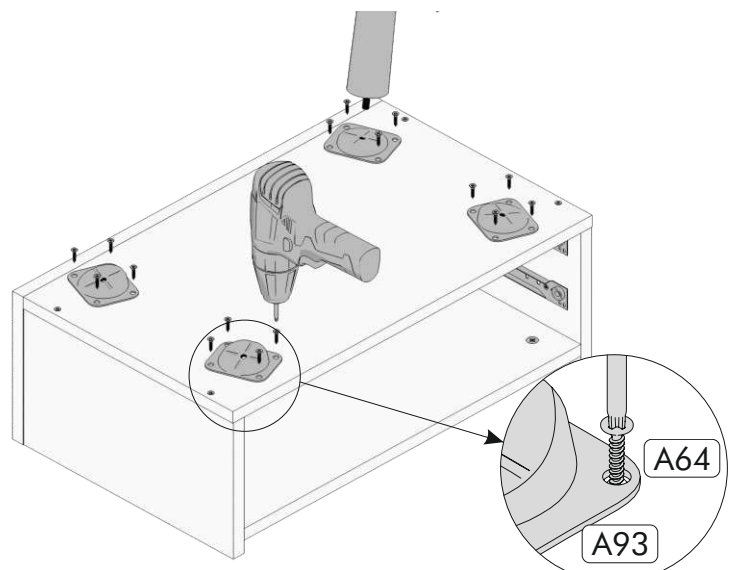

ASSEMBLY

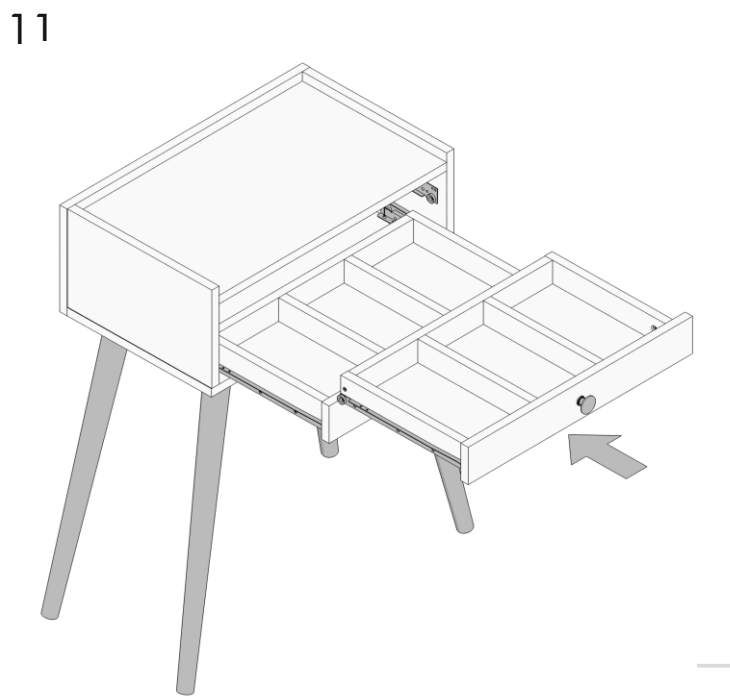
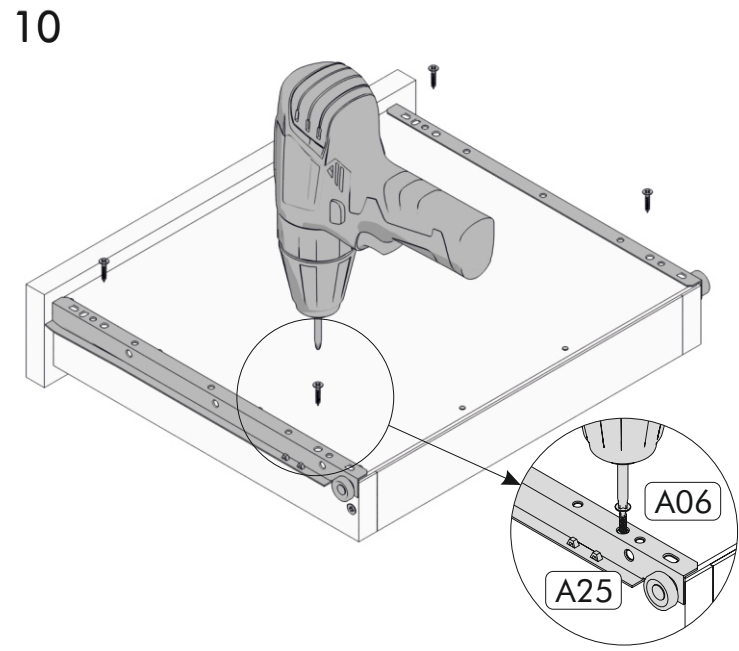
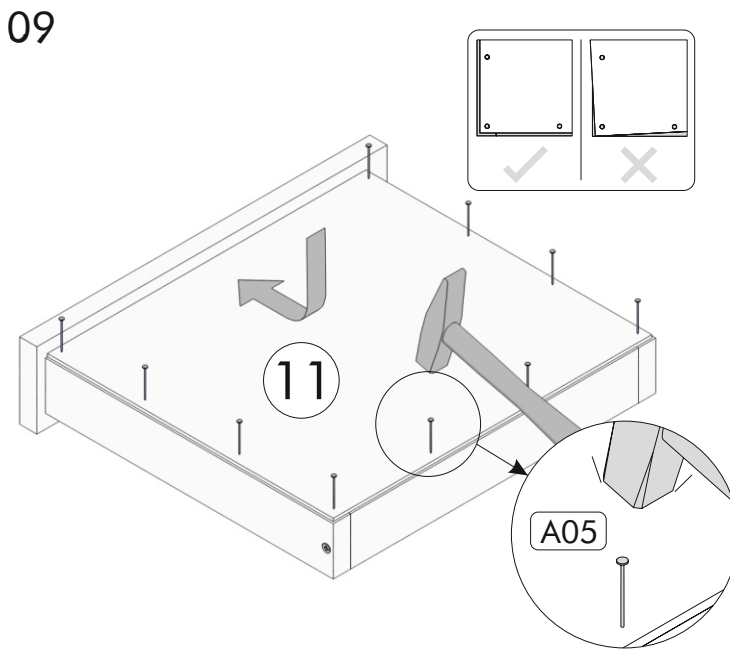
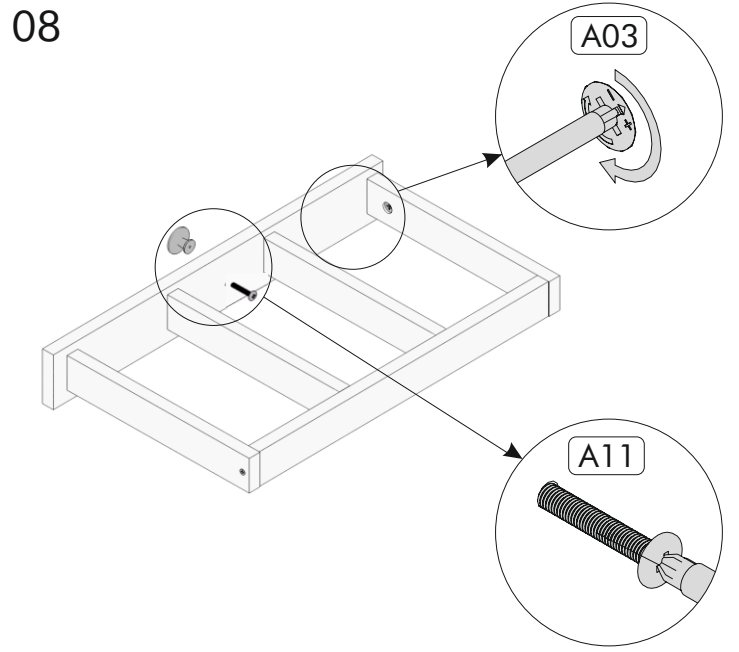
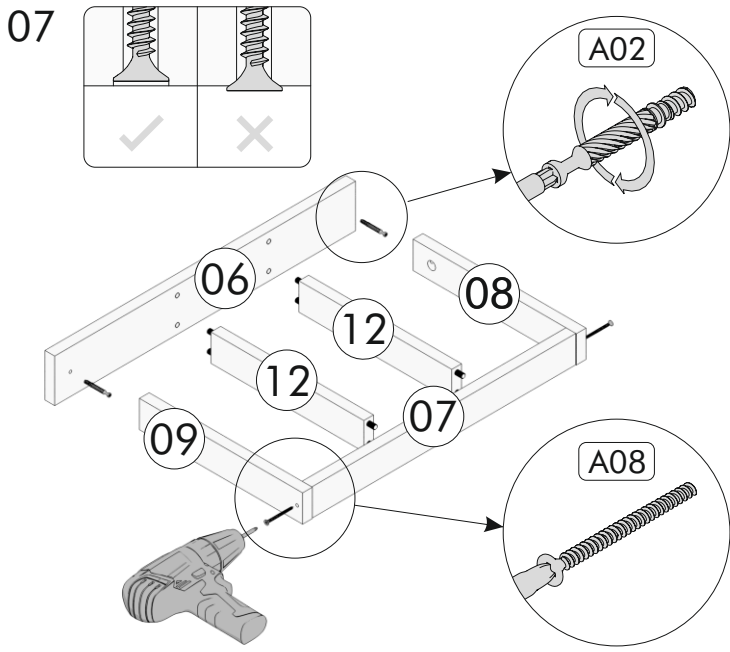

ASSEMBLY

12

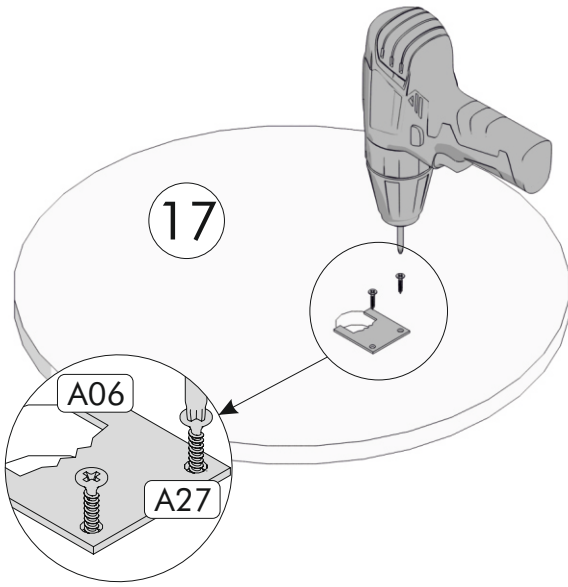

13

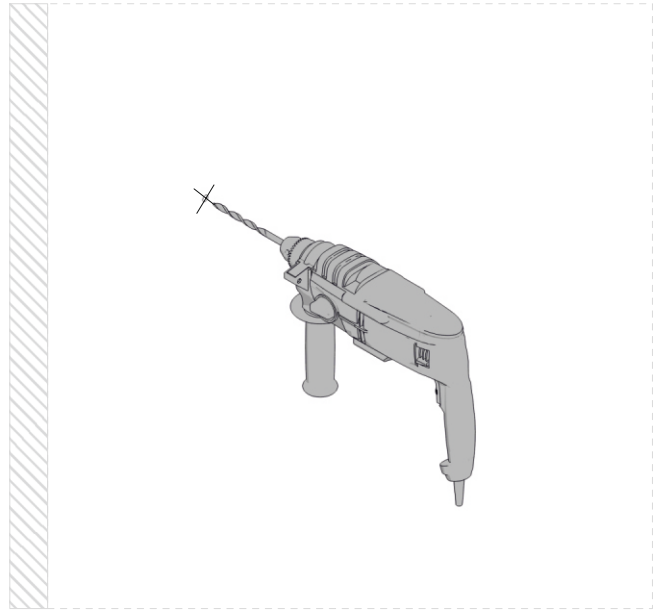

14

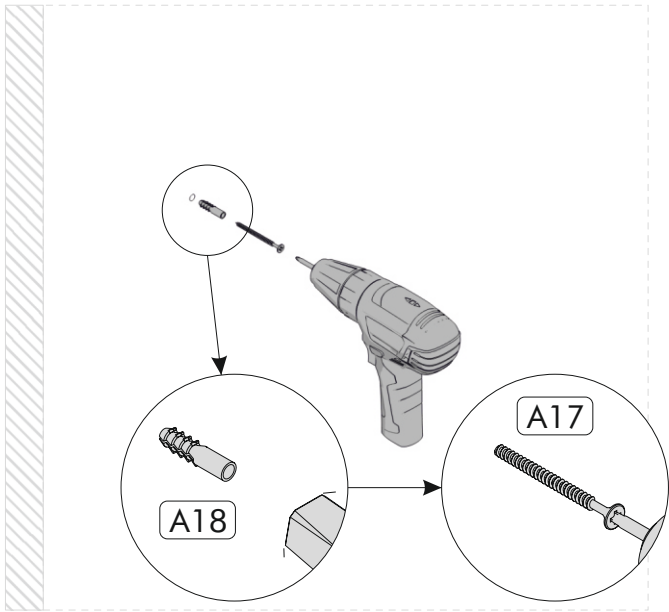

15

