

CAUTION:

To clean use soft, dry cloth. Do not use detergent or chemicals
Avoid contact with water and direct sunlight.
To be assembled on a soft, dry, clean and smooth surface.

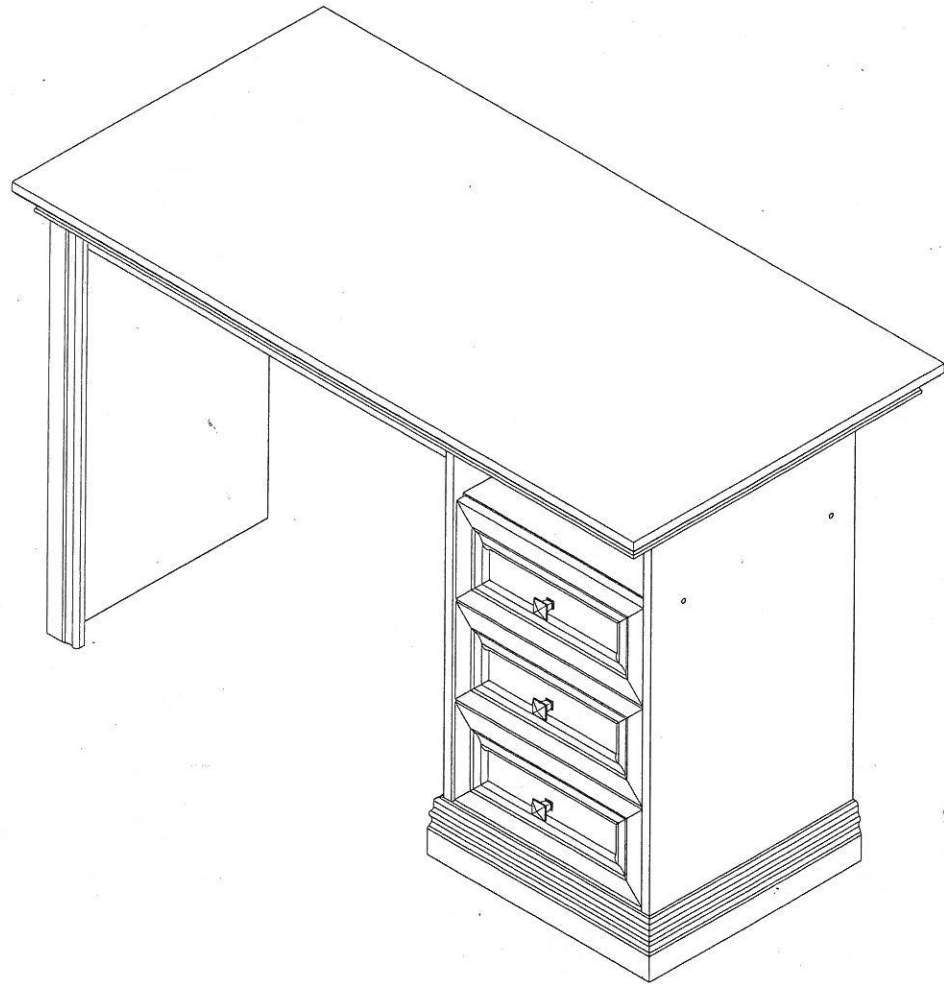

COMPLETE SET

ORDERING REPAIR PARTS

In order to obtain smooth and rapid service when ordering repair parts,
please give full attention to the following of PART NUMBER.

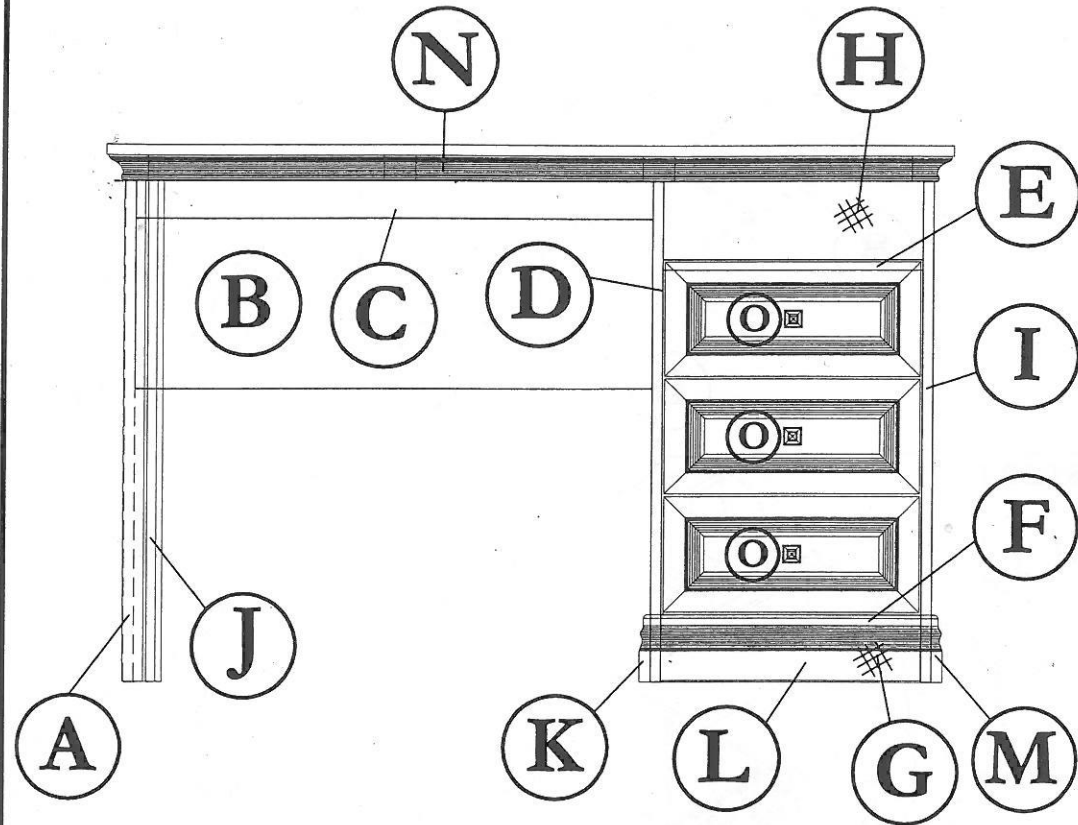

NO	DESCRIPTION	QTY
A	LEFT SIDE	01
B	BACK (Left)	01
C	TOP SUPPORT	01
D	CENTRE VERTICAL	01
E	CENTRE SHELF	01
F	LOWER SHELF	02
G	LEG	02
H	BACK	01

NO	DESCRIPTION	QTY
I	RIGHT SIDE	01
J	LEFT SIDE WRAPPING	01
K	WRAPPING (Left)	01
L	WRAPPING (Front)	01
M	WRAPPING (Right)	01
N	TABLE TOP	01
O	DRAWER FACE	03

ASSEMBLY INSTRUCTION
MODEL : 6096 / OFFICE TABLE

Before you begin, please follow assembly instruction carefully.
 Then follow them step by step.

STEP 1

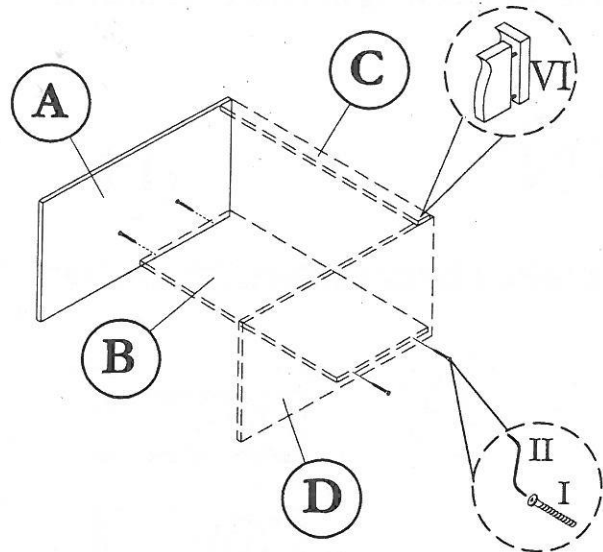

STEP 2

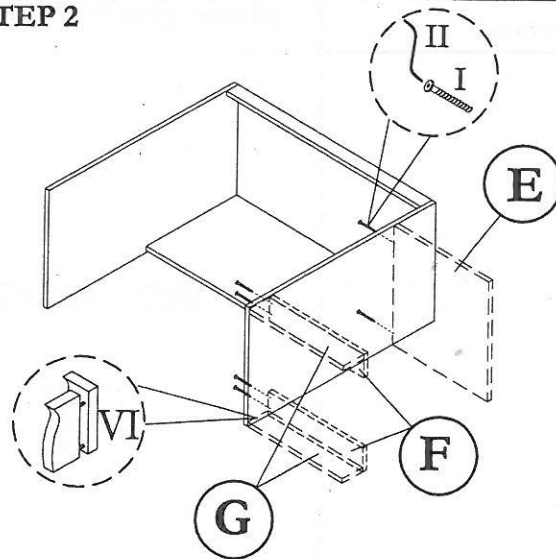

STEP 3

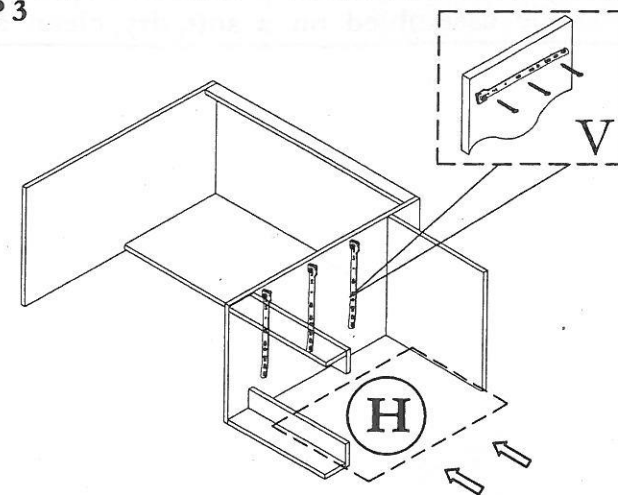

STEP 4

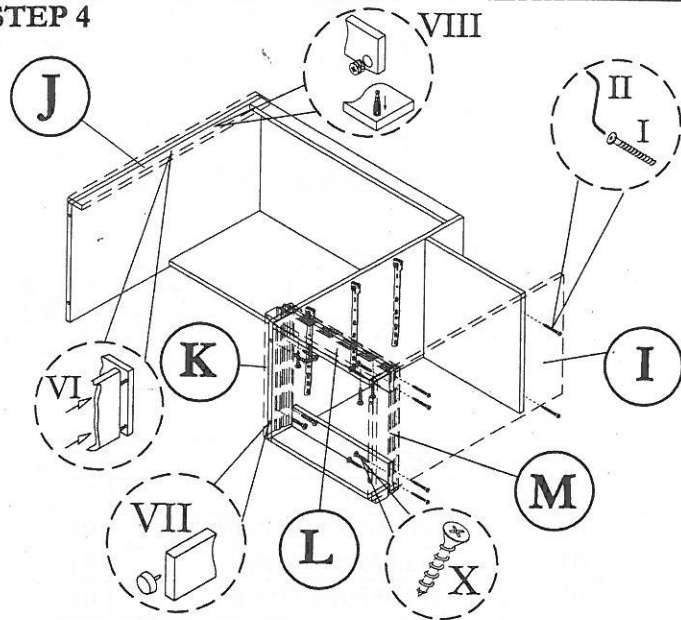

STEP 5

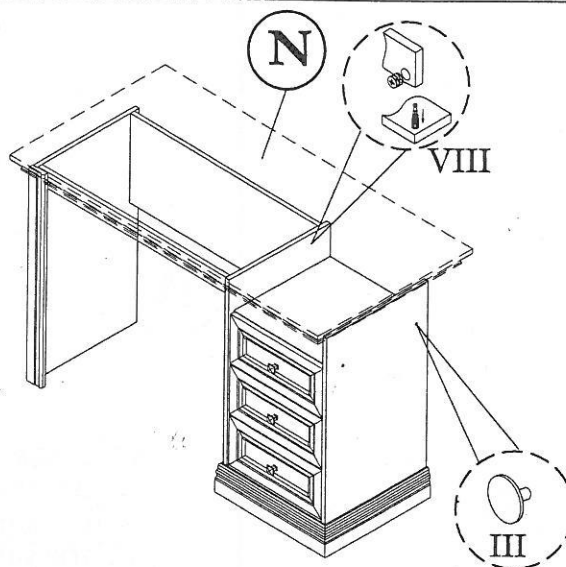

STEP 6

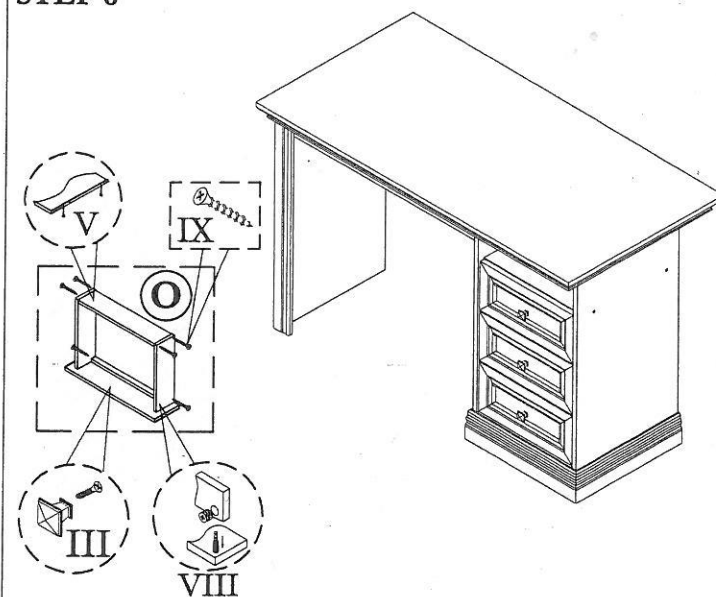

HARDWARE LIST			
NO	DESCRIPTION		QTY
I	JCBCW SCREW M6 x 45		16pcs
II	M4 ALLEN KEY		1pc
III	CAP SMALL		6pcs

IV	HANDLE & SCREW M4 x 12		3sets
V	12" DRAWER SLIDER & SCREW M3.5 x 12		3sets
VI	M8 x 30 PLASTIC DOWEL		13pcs
VII	PVC NAIL WITH PIN		6pcs
VIII	Q-FIT		20sets

IX	M8 x 32 CHIPBOARD SCREW		18pcs
X	M4 x 25 CHIPBOARD SCREW		12pcs