

CAUTION:

To clean use soft, dry cloth. Do not use detergent or chemicals
Avoid contact with water and direct sunlight.
To be assembled on a soft, dry, clean and smooth surface.

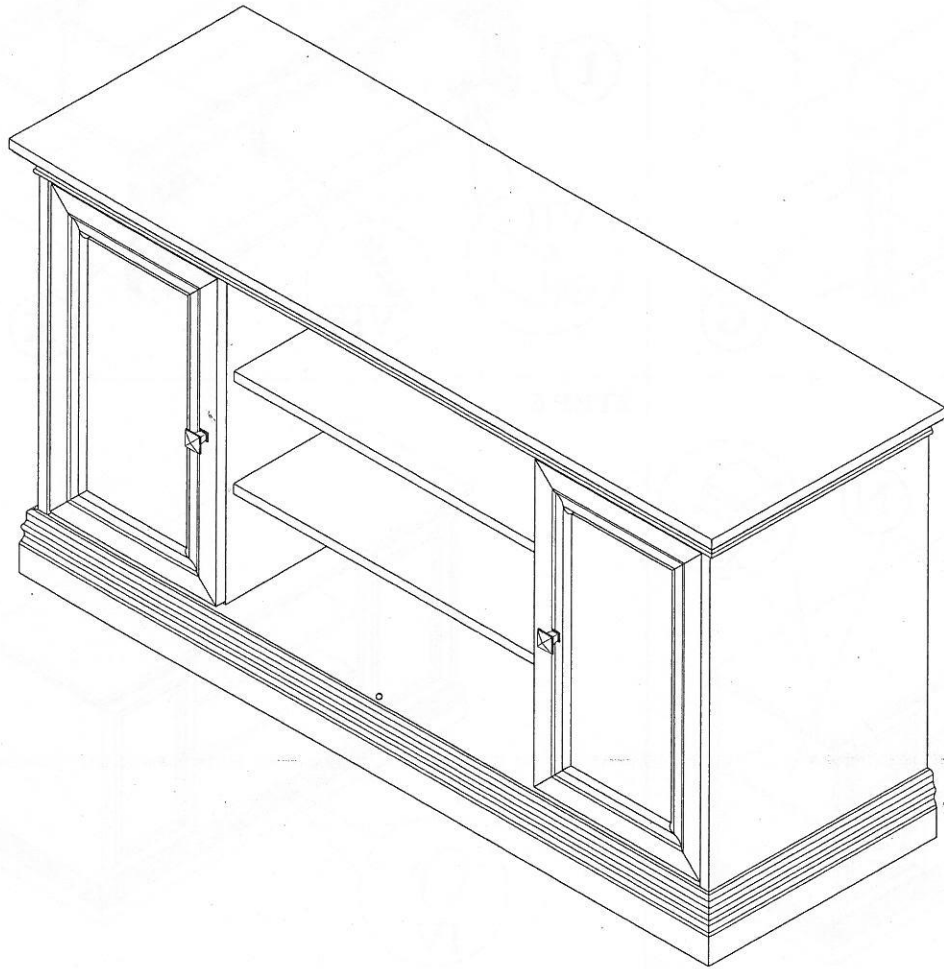

COMPLETE SET

ORDERING REPAIR PARTS

In order to obtain smooth and rapid service when ordering repair parts, please give full attention to the following of PART NUMBER.

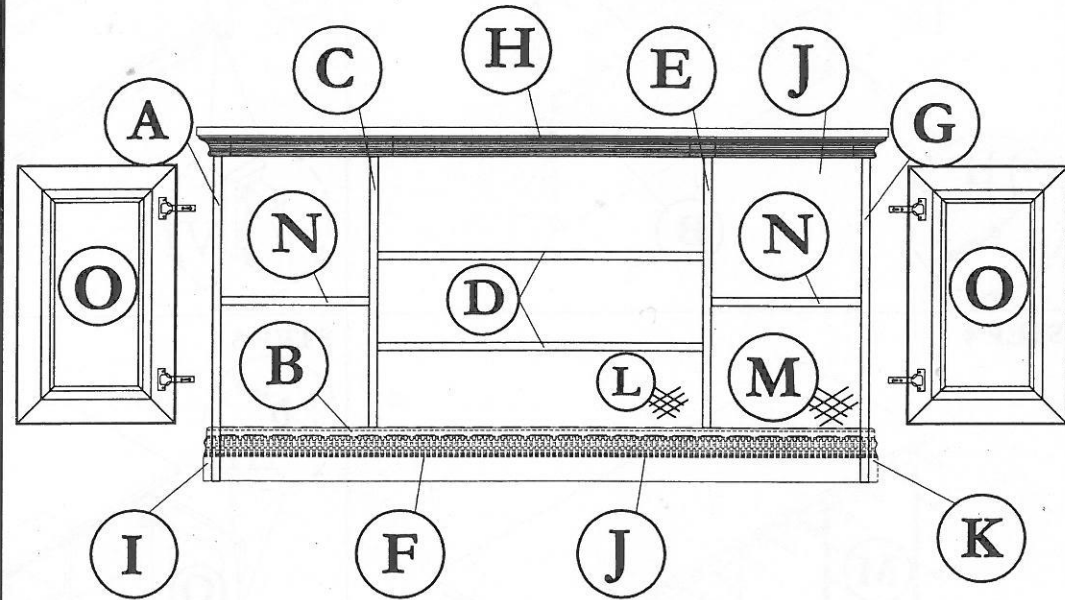

NO	DESCRIPTION	QTY
A	LEFT SIDE	01
B	LOWER SHELF	01
C	CENTRE VERTICAL	01
D	CENTRE SHELF	02
E	CENTRE VERTICAL	01
F	LEG	02
G	RIGHT SIDE	01
H	TOP	01

NO	DESCRIPTION	QTY
I	WRAPPING (Left)	01
J	WRAPPING (Front)	01
K	WRAPPING (Right)	01
L	BACK (Centre)	01
M	BACK (Left/Right)	02
N	MOVABLE SHELF	02
O	DOOR	02

ASSEMBLY INSTRUCTION

MODEL : 8263 / TV CABINET

Before you begin, please follow assembly instruction carefully.
Then follow them step by step.

STEP 1

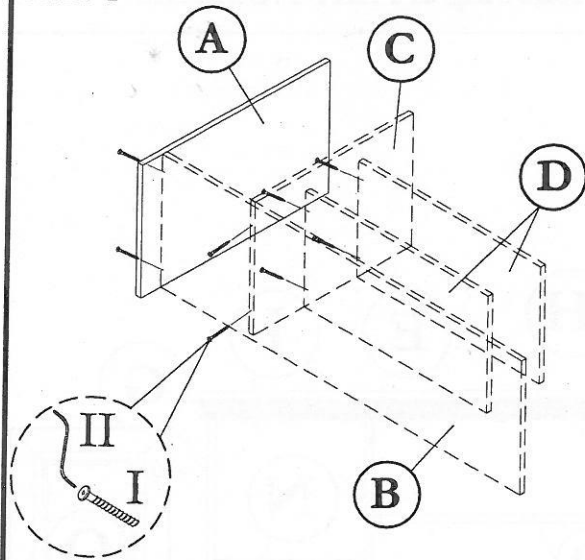

STEP 2

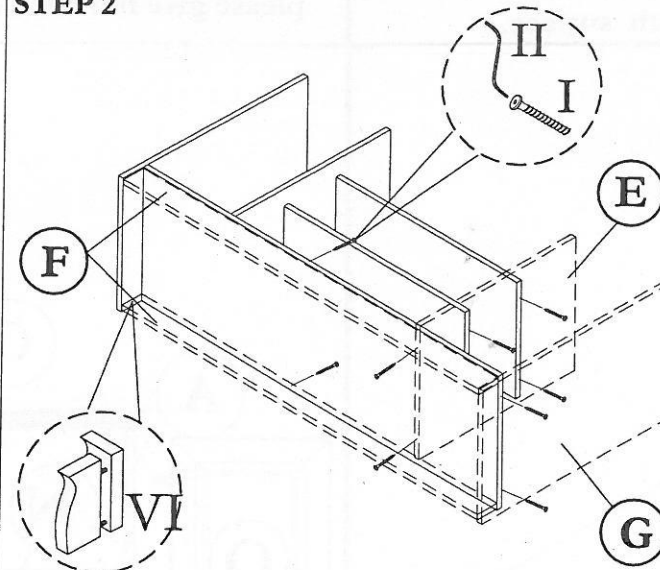

STEP 3

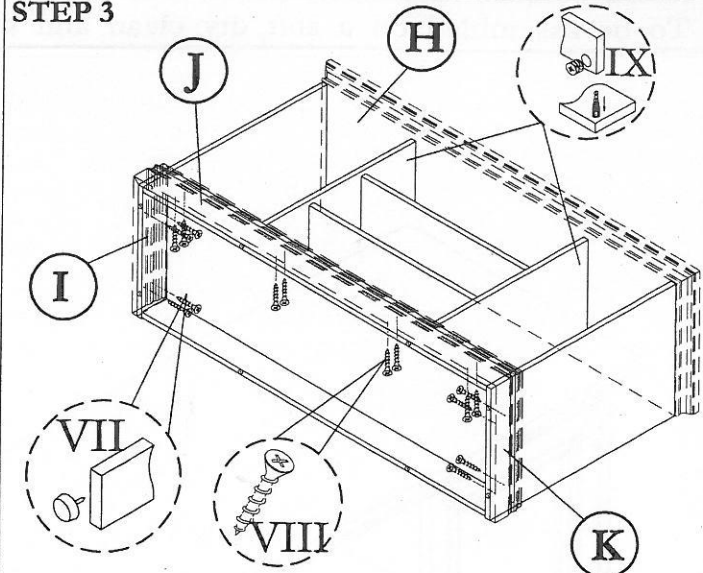

STEP 4

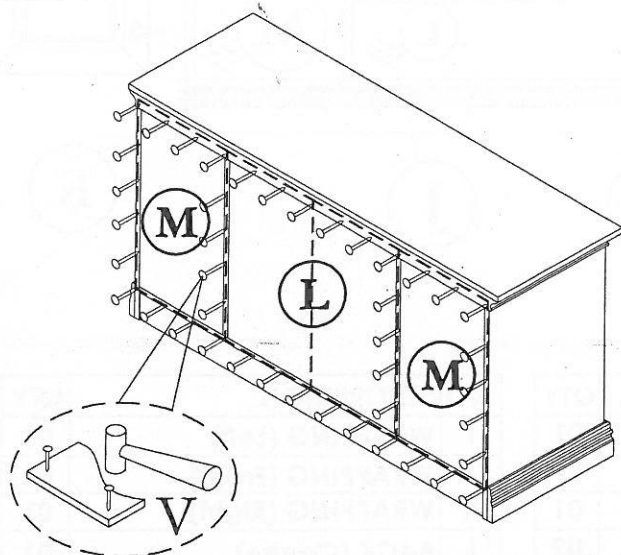

STEP 5

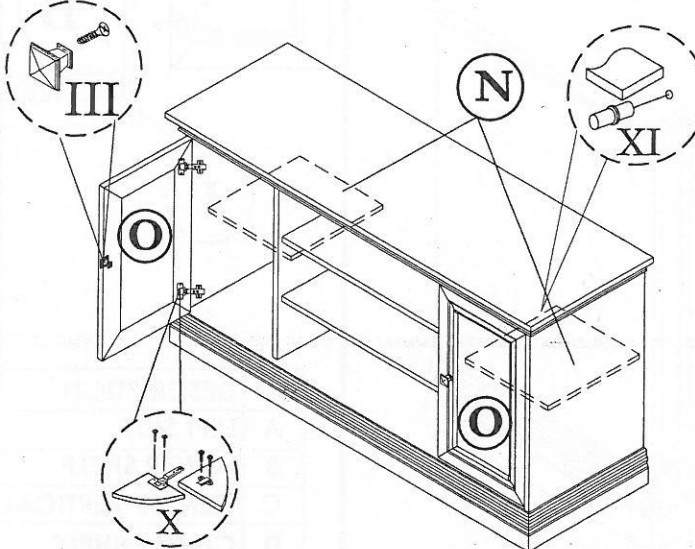

STEP 6

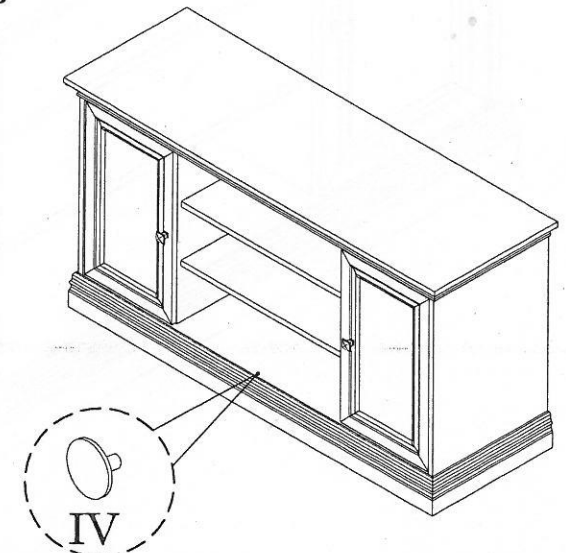

HARDWARE LIST

NO	DESCRIPTION	QTY
I	JCBCW SCREW M6 x 45	18pcs
II	M4 ALLEN KEY	1pc
III	HANDLE & SCREW M4 x 22	2sets

IV	CAP SMALL	2pcs
V	NAIL	50pcs
VI	M8 x 30 PLASTIC DOWEL	8pcs
VII	PVC NAIL WITH PIN	8pcs
VIII	M4 x 25 CHIPBOARD SCREW	16pcs

IX	Q-FIT	8sets
X	HINGE (C) & SCREW M3.5 x 16	4sets
XI	SHELF SUPPORT	8pcs