

CAUTION:

To clean use soft, dry cloth. Do not use detergent or chemicals
 Avoid contact with water and direct sunlight.
 To be assembled on a soft, dry, clean and smooth surface.

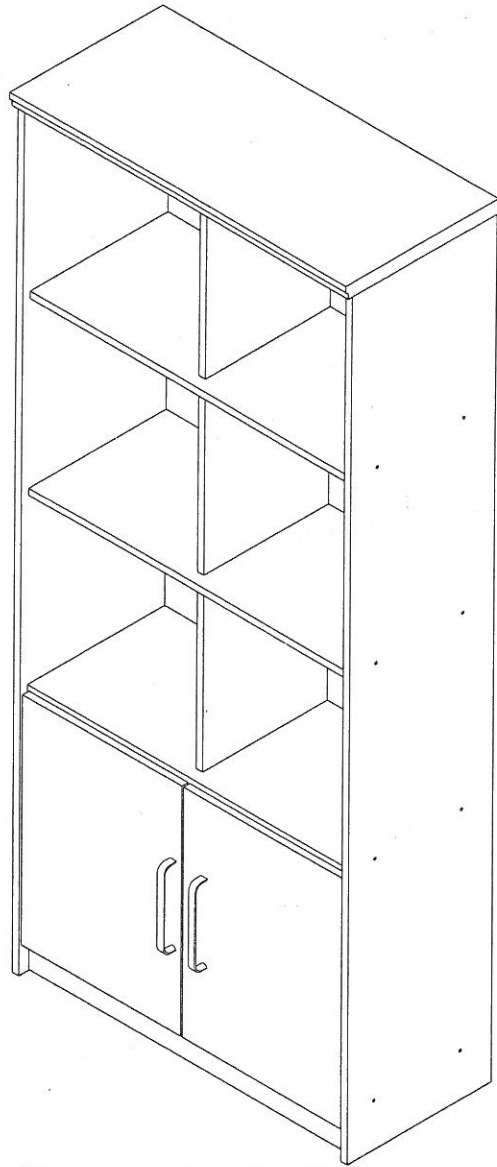

COMPLETE SET

ORDERING REPAIR PARTS

In order to obtain smooth and rapid service when ordering repair parts, please give full attention to the following of PART NUMBER.

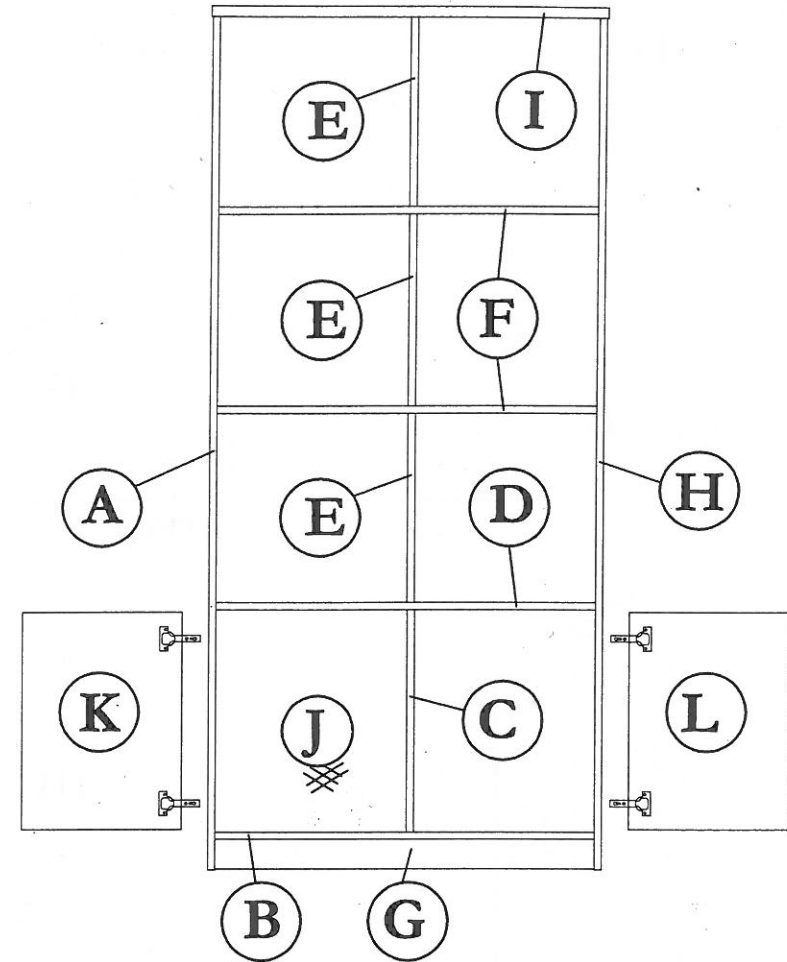

NO	DESCRIPTION	QTY
A	LEFT SIDE	01
B	LOWER SHELF	01
C	CENTRE VERTICAL (Bottom)	01
D	CENTRE SHELF	01
E	CENTRE VERTICAL	03
F	CENTRE SHELF	02

NO	DESCRIPTION	QTY
G	LEG	02
H	RIGHT SIDE	01
I	TOP	01
J	BACK	02
K	LEFT SIDE DOOR	01
L	RIGHT SIDE DOOR	01

ASSEMBLY INSTRUCTION
MODEL : 1186-PK / BOOKCASE

Before you begin, please follow assembly instruction carefully.
 Then follow them step by step.

STEP 1

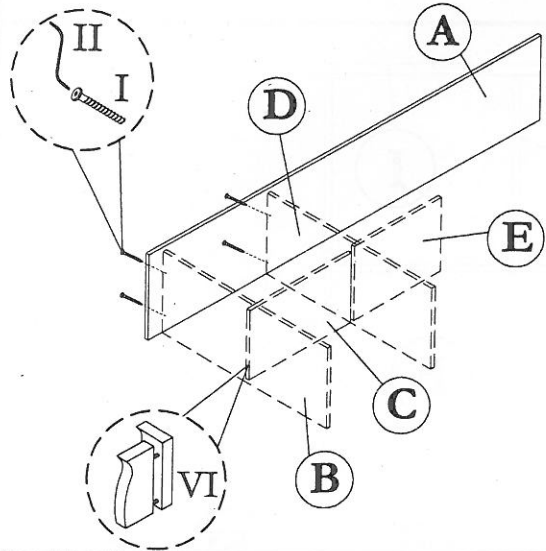

STEP 2

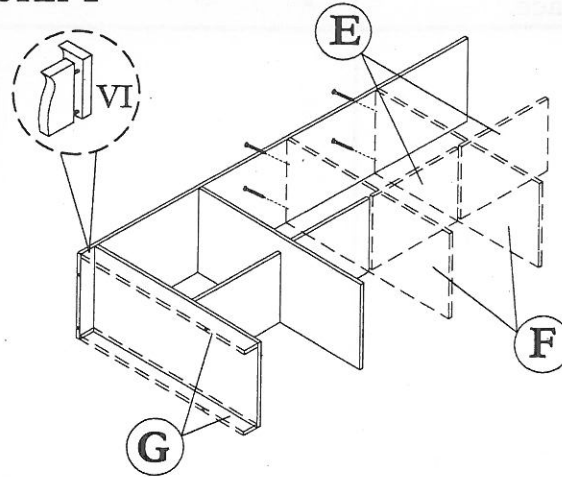

STEP 3

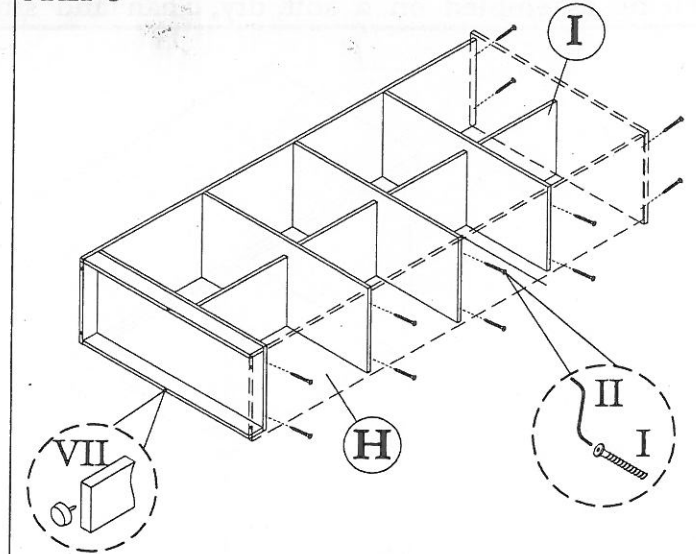

STEP 4

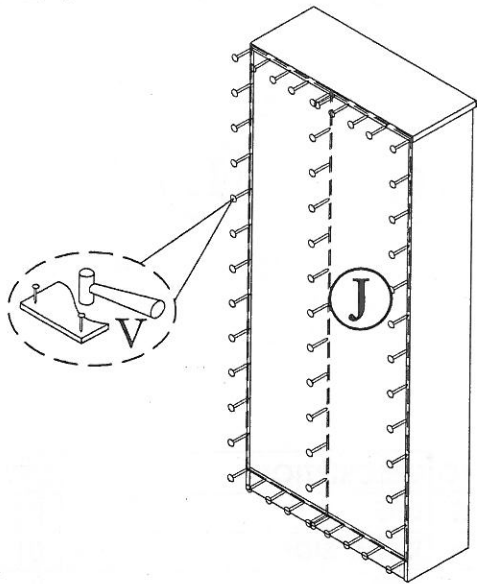

STEP 5

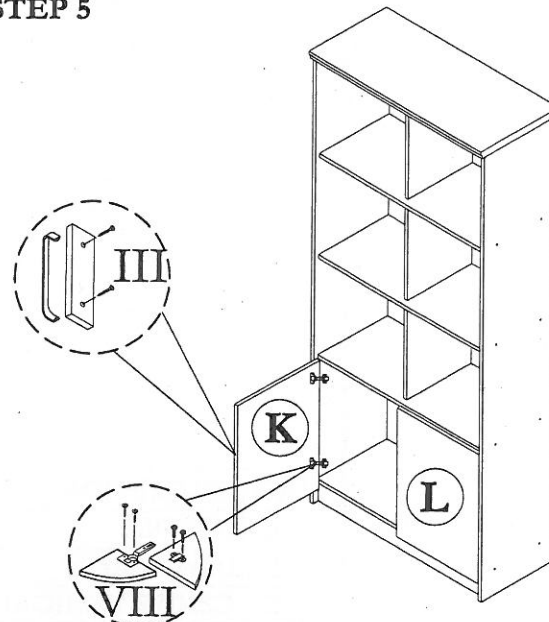

STEP 6

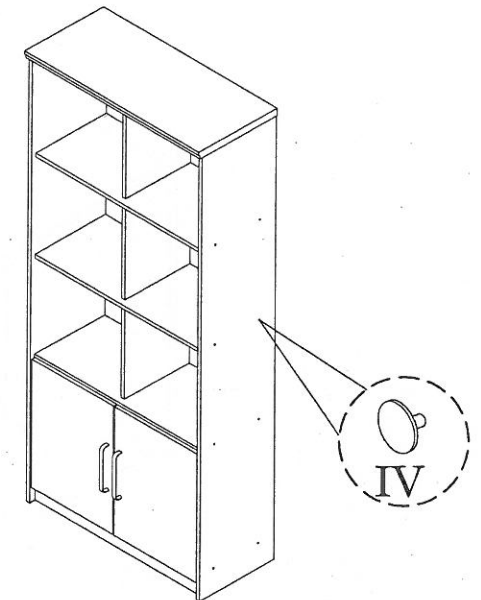

HARDWARE LIST

NO	DESCRIPTION	QTY
I	JCBCW SCREW M6 x 45	20pcs
II	M4 ALLEN KEY	1pc

III	HANDLE & SCREW M3.5 x 30	2sets
IV	CAP SMALL	16pcs
V	NAIL	60pcs
VI	M8 x 30 PLASTIC DOWEL	24pcs

VII	PVC NAIL WITH PIN	6pcs
VIII	HINGES (C) & SCREW M3.5 x 16	4sets