

CAUTION:

To clean use soft, dry cloth. Do not use detergent or chemicals
Avoid contact with water and direct sunlight.
To be assembled on a soft, dry, clean and smooth surface.

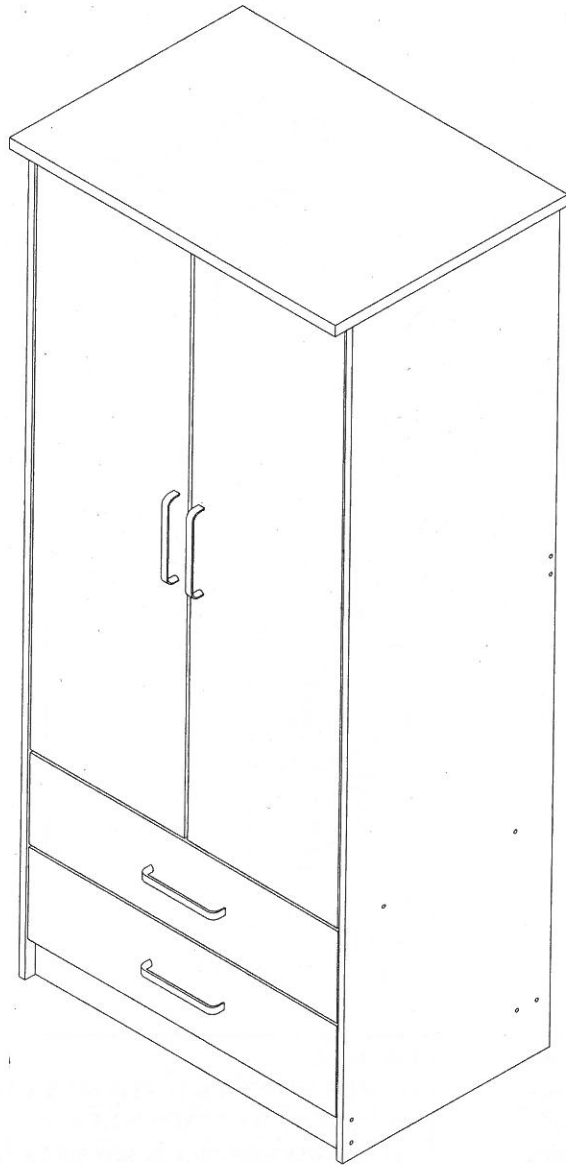

COMPLETE SET

ORDERING REPAIR PARTS

In order to obtain smooth and rapid service when ordering repair parts,
please give full attention to the following of PART NUMBER.

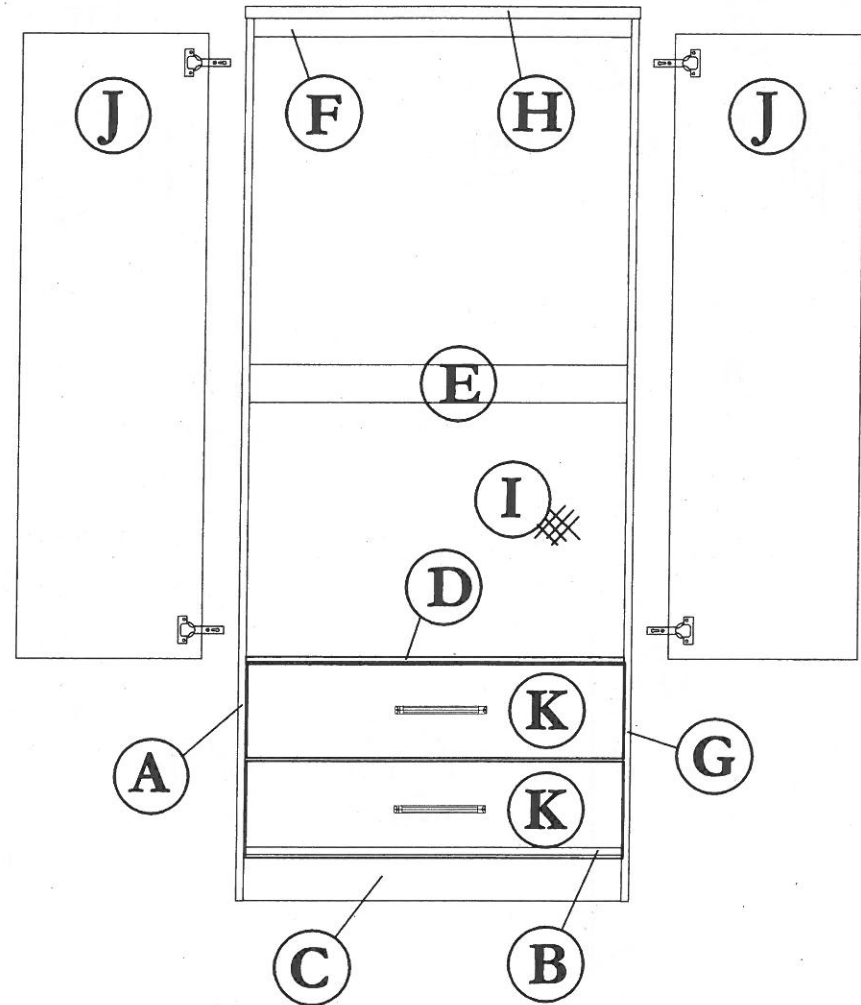

NO	DESCRIPTION	QTY
A	LEFT SIDE	01
B	LOWER SHELF	01
C	LEG	01
D	CENTRE SHELF	01
E	BACK SUPPORT	01
F	TOP SUPPORT	01

NO	DESCRIPTION	QTY
G	RIGHT SIDE	01
H	TOP	01
I	BACK	02
J	LEFT/RIGHT SIDE DOOR	02
K	DRAWER FACE	02

ASSEMBLY INSTRUCTION
MODEL : 9261 D / WARDROBE

Before you begin, please follow assembly instruction carefully.
 Then follow them step by step.

STEP 1

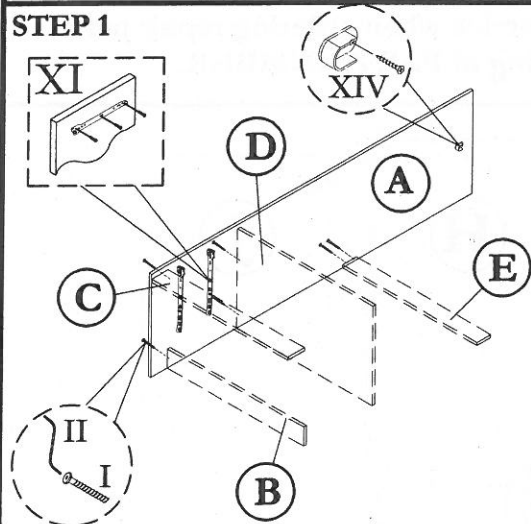

STEP 2

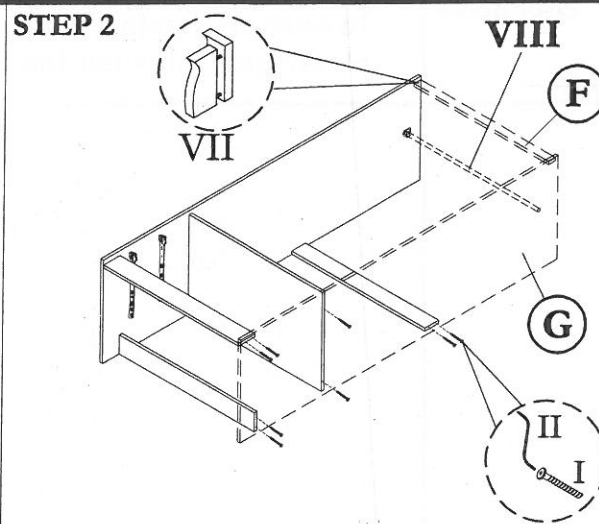

STEP 3

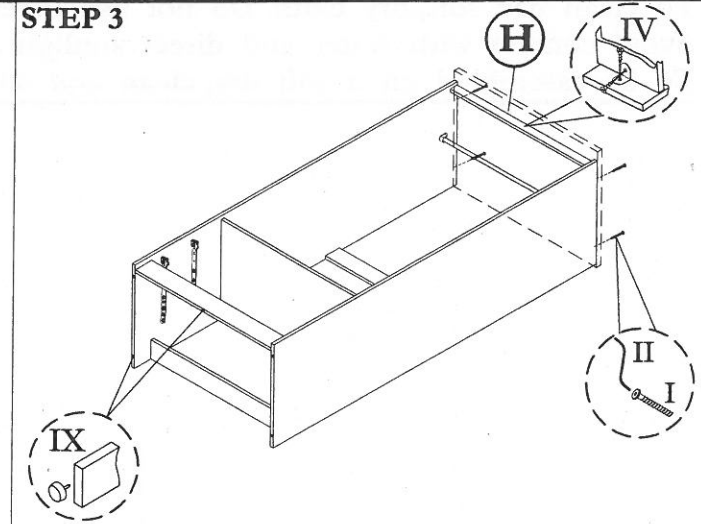

STEP 4

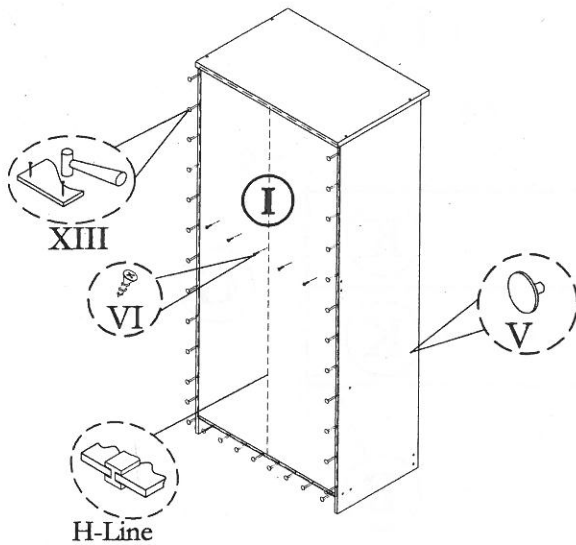

STEP 5

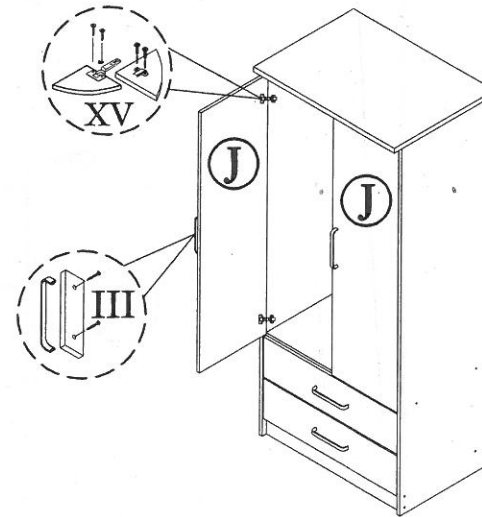

STEP 6

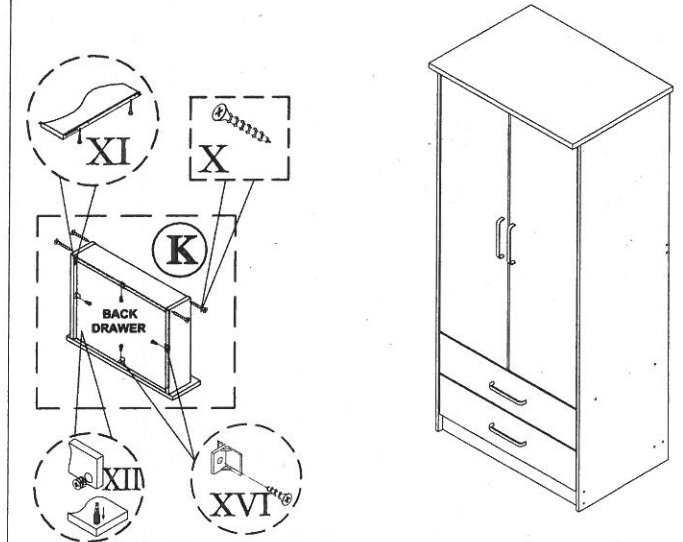

HARDWARE LIST

NO	DESCRIPTION	QTY
I	JCBCW SCREW M6 x 45	20pcs
II	M4 ALLEN KEY	1pc
III	HANDLE & SCREW M3.5 x 30	4sets
IV	L BRACKET & SCREW M3.5 x 12	1sets
V	CAP SMALL	16pcs

VI	M3.5 x 12 CHIPBOARD SCREW	5pcs
VII	PLASTIC DOWEL	2pcs
VIII	PIPE SIZE : 30 $\frac{0.5}{8}$	1pc
IX	PVC NAIL WITH PIN	5pcs
X	M8 x 32 CHIPBOARD SCREW	8pcs
XI	14" DRAWER SLIDER & SCREW M3.5 x 12	2sets
XII	Q-FIT	8sets

XIII	NAIL	80pcs
XIV	PIPE SUPPORT & SCREW M3.5 x 16	2sets
XV	HINGE (C) & SCREW M3.5 x 16	4sets
XVI	DRAWER SUPPORT & SCREW M3.5 x 12	8sets