

CAUTION:

To clean use soft, dry cloth. Do not use detergent or chemicals
 Avoid contact with water and direct sunlight.
 To be assembled on a soft, dry, clean and smooth surface.

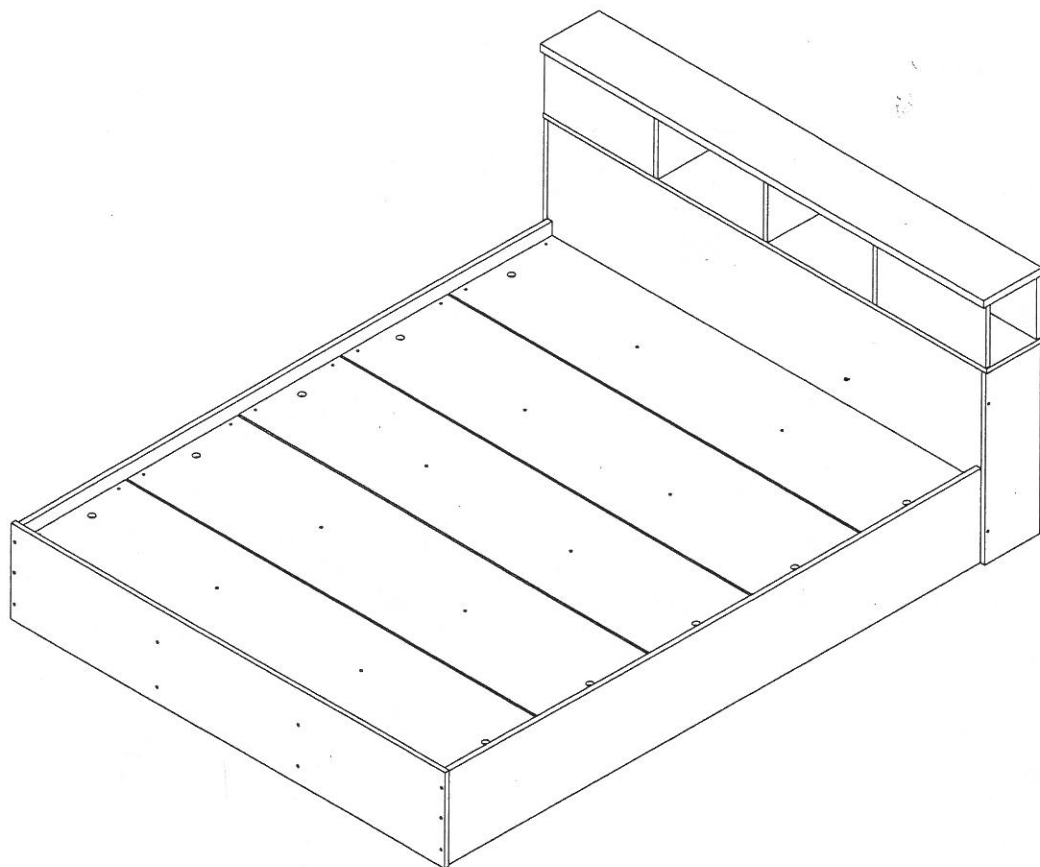

COMPLETE SET

ORDERING REPAIR PARTS

In order to obtain smooth and rapid service when ordering repair parts, please give full attention to the following of PART NUMBER.

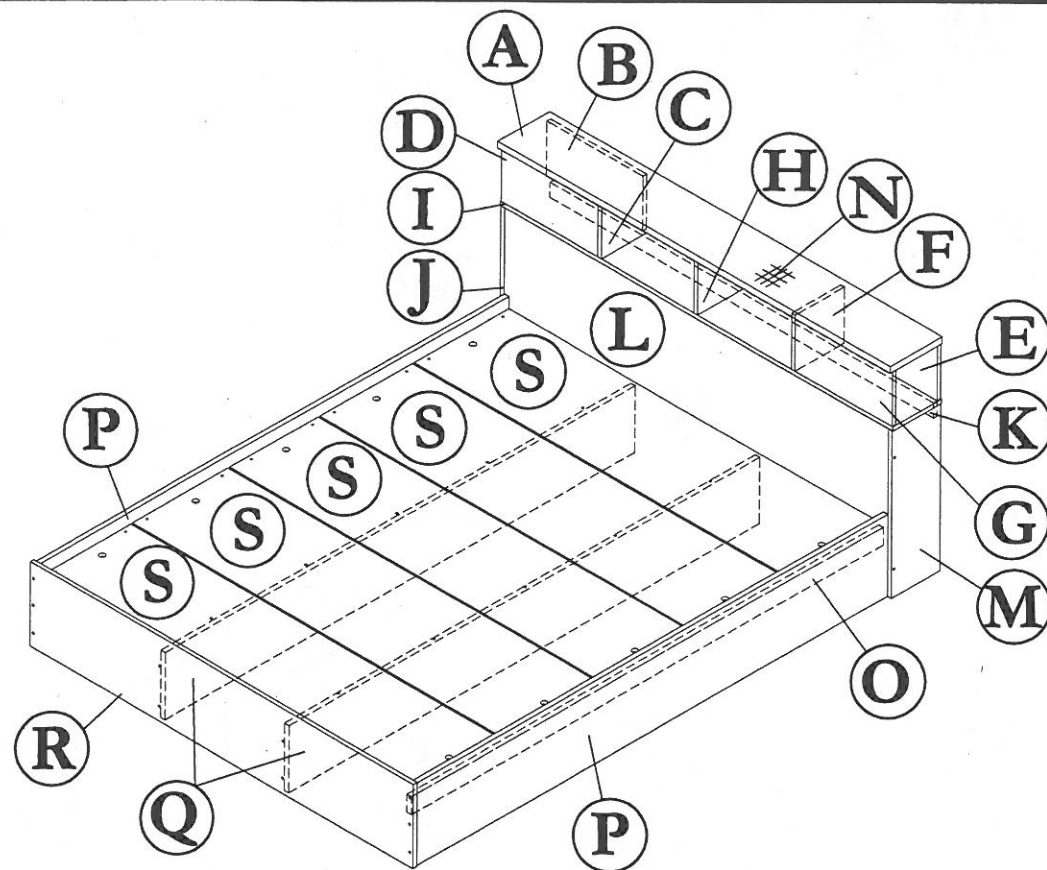

NO	DESCRIPTION	QTY
A	TOP	01
B	LEFT SIDE BACK VERTICAL (Head)	01
C	CENTRE VERTICAL (Head)	01
D	LEFT SIDE FRONT VERTICAL (Head)	01
E	RIGHT SIDE BACK VERTICAL (Head)	01
F	CENTRE VERTICAL (Head)	01
G	RIGHT SIDE FRONT VERTICAL (Head)	01
H	CENTRE VERTICAL (Head)	01
I	CENTRE SHELF (Head)	01
J	LEFT SIDE (Head)	01

NO	DESCRIPTION	QTY
K	CENTRE SHELF SUPPORT (Head)	01
L	BACK VERTICAL (Head)	01
M	RIGHT SIDE (Head)	01
N	BACK (Head)	01
O	SIDE SUPPORT (Body)	02
P	SIDE (Body)	02
Q	CENTRE VERTICAL (Body)	02
R	FRONT VERTICAL (Body)	01
S	DECORATIVE BOARD	05

ASSEMBLY INSTRUCTION

MODEL : 4855 DB / DOUBLE BED

Before you begin, please follow assembly instruction carefully.
Then follow them step by step.

STEP 1

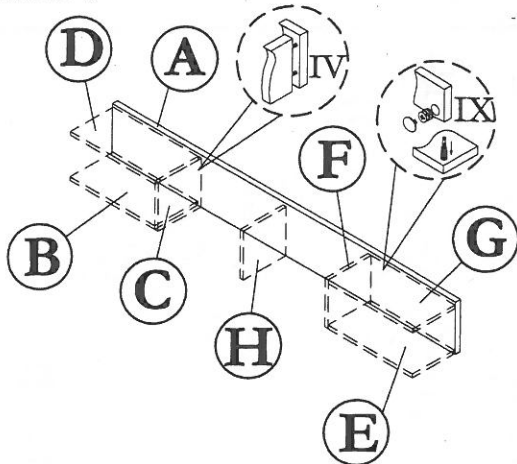

STEP 2

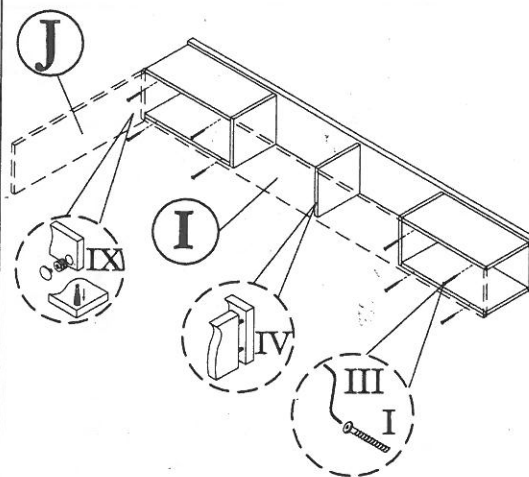

STEP 3

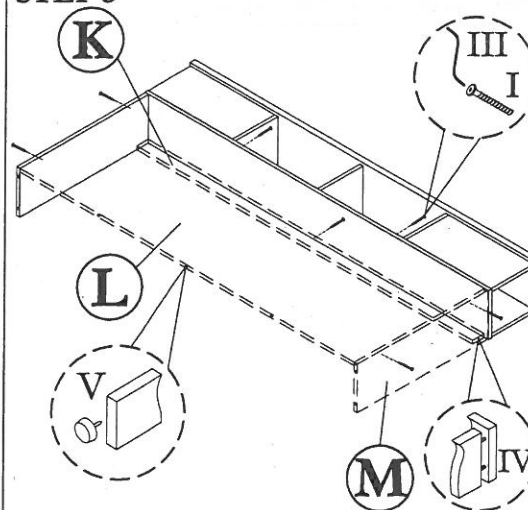

STEP 4

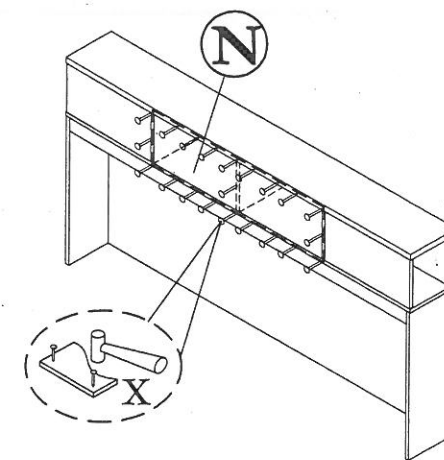

STEP 5

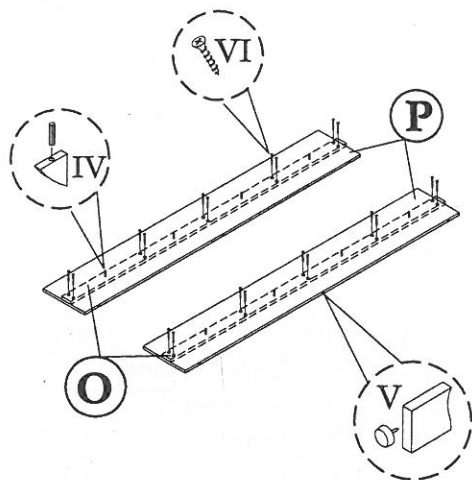

STEP 6

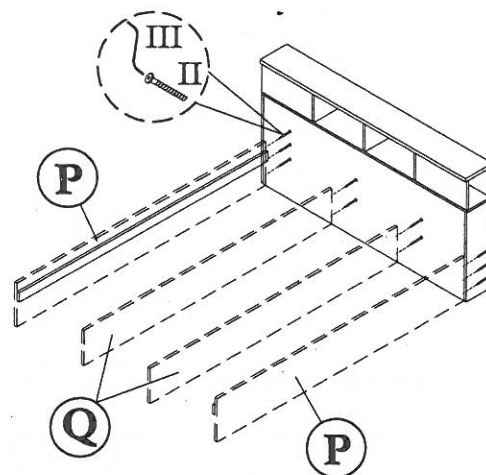

STEP 7

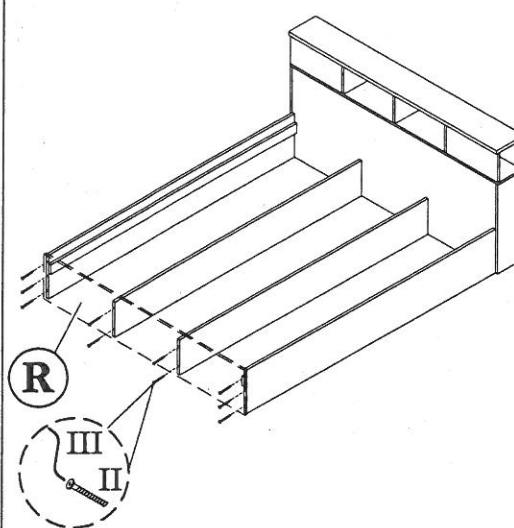

STEP 8

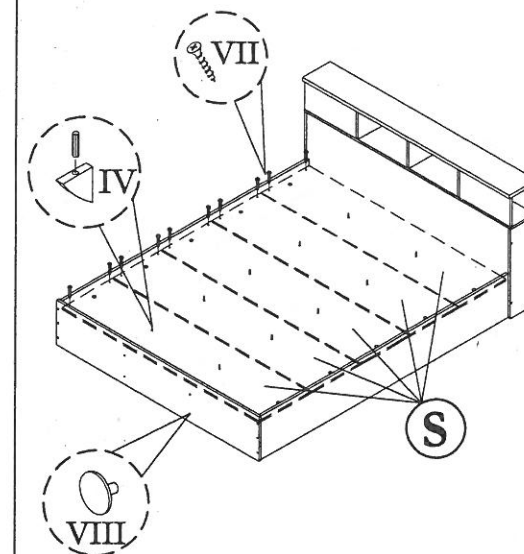

HARDWARE LIST

NO	DESCRIPTION	QTY
I	JCBCW SCREW M6 x 45	15pcs
II	JCBCW SCREW M6 x 60	20pcs
III	M4 ALLEN KEY	1pc

IV	M8 x 30 PLASTIC DOWEL	34pcs
V	PVC NAIL WITH PIN	22pcs
VI	M3.5 x 30 CHIPBOARD SCREW	20pcs
VII	M4 x 25 CHIPBOARD SCREW	20pcs
VIII	CAP SMALL	16pcs

IX	Q-FIT	12sets
X	NAIL	20pcs