

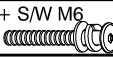



ASSEMBLY INSTRUCTIONS

MODEL : WM1938-DC

IMPORTANT NOTE :

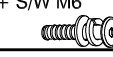
- * PLACE ALL WOODEN PARTS ON A CLEAN AND SMOOTH SURFACE SUCH AS A RUG OR CARPET TO AVOID THE PARTS FROM BEING SCRATCHED.
- * BEFORE YOU BEGIN, KINDLY FOLLOW THE ASSEMBLY INSTRUCTIONS STEP BY STEP.
- * DO NOT TIGHTEN ALL SCREWS UNTIL THE CHAIR IS FULLY SET-UP.

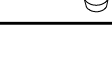
HARDWARE LIST			PART LIST		
A	JCBC M6 x 50mm + S/W M6 + F/W M6 x 13mm 	4PCS	1	FRONT LEG FRAME	1PC
B	JCBC M6 x 35mm + S/W M6 + F/W M6 x 13mm 	4PCS	2	BACK LEG FRAME	1PC
C	JCBC M6 x 30mm + S/W M6 + F/W M6 x 13mm 	4PCS	3	SIDE STRETCHER (L&R)	1PC
D	ALLEN KEY M4 	1PC	4	CUSHION SEAT	1PC
E	WOOD BUTTON Ø14.5mm 	4PCS	5	TOP REST	1PC

CAUTIONS :

(1) **DO NOT FULLY-TIGHTEN THE NUT OR NUT BOLTS INITIALLY UNTIL ALL NUTS OR BOLT IS READY ASSEMBLED.**

(TO AVOID CAUSING DAMAGES TO THE THREAD, DO NOT OVER-TIGHTEN THE NUTS OR BOLTS.)

(2) **KEEP ALL HARDWARE PART OUT OF REACH OF CHILDREN.**

STEP 1

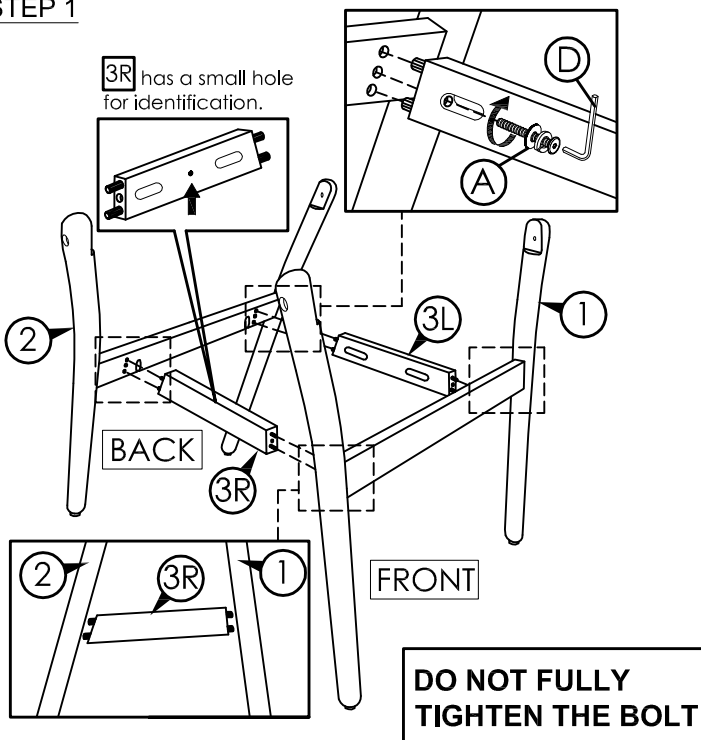

STEP 2

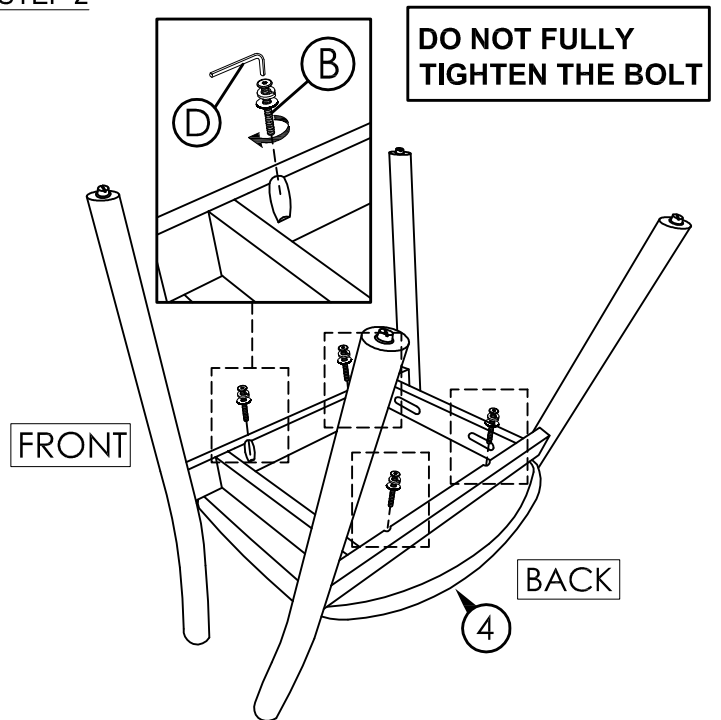

STEP 3

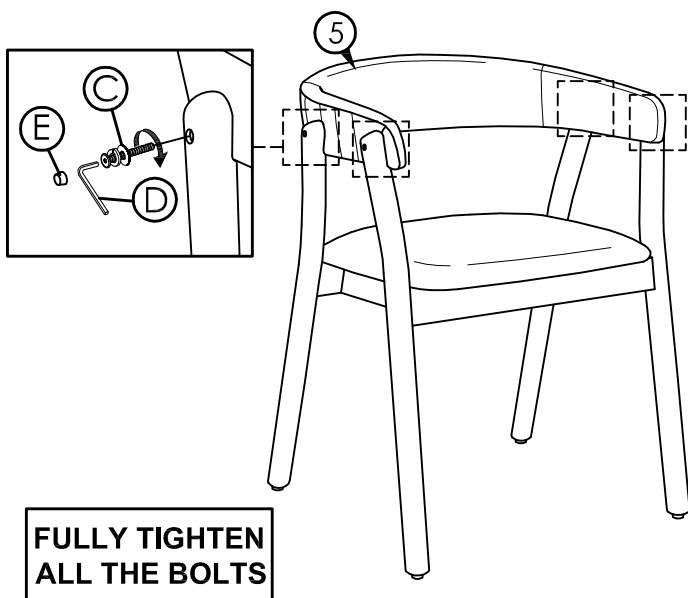

STEP 4

