

ASSEMBLY INSTRUCTIONS

MODEL : WM1889-DC

IMPORTANT NOTE :

- * PLACE ALL WOODEN PARTS ON A CLEAN AND SMOOTH SURFACE SUCH AS A RUG OR CARPET TO AVOID THE PARTS FROM BEING SCRATCHED.
- * BEFORE YOU BEGIN, KINDLY FOLLOW THE ASSEMBLY INSTRUCTIONS STEP BY STEP.
- * DO NOT TIGHTEN ALL SCREWS UNTIL THE CHAIR IS FULLY SET-UP.

HARDWARE LIST		PART LIST	
A	JCBC M6 x 25mm + S/W M6 + F/W M6 x 13mm	4PCS	1 LEG L/R 2PCS
	B	JCBC M6 x 55mm + S/W M6 + F/W M6 x 13mm	4PCS
C		JCBC W SCREW M7 x 40mm	1PC
	D	FH SCREW #8 x 25mm	16PCS
E		ALLEN KEY M4	1PC

CAUTIONS :

(1) **DO NOT FULLY-TIGHTEN THE NUT OR NUT BOLTS INITIALLY UNTIL ALL NUTS OR BOLT IS READY ASSEMBLED.**

(TO AVOID CAUSING DAMAGES TO THE THREAD, DO NOT OVER-TIGHTEN THE NUTS OR BOLTS.)

(2) **KEEP ALL HARDWARE PART OUT OF REACH OF CHILDREN.**

STEP 1

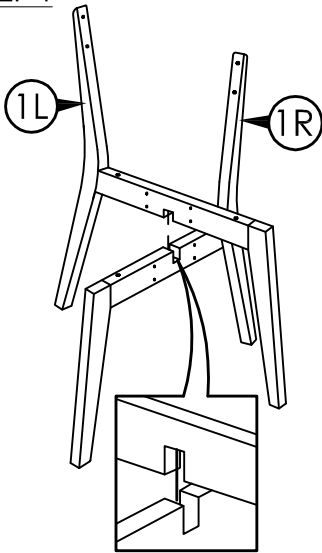

STEP 2

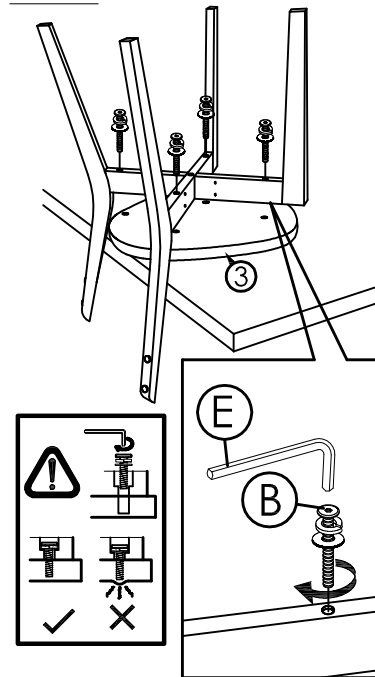

STEP 3

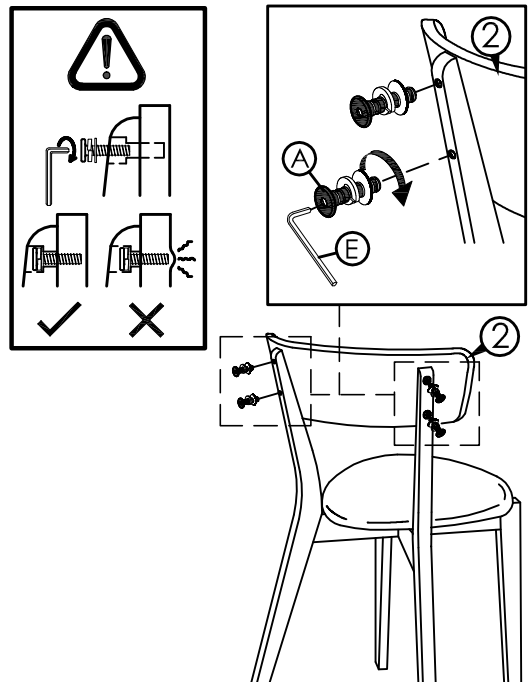

STEP 4

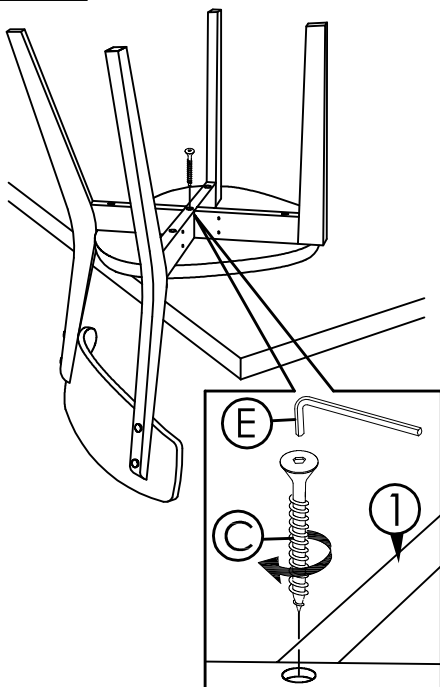

STEP 5

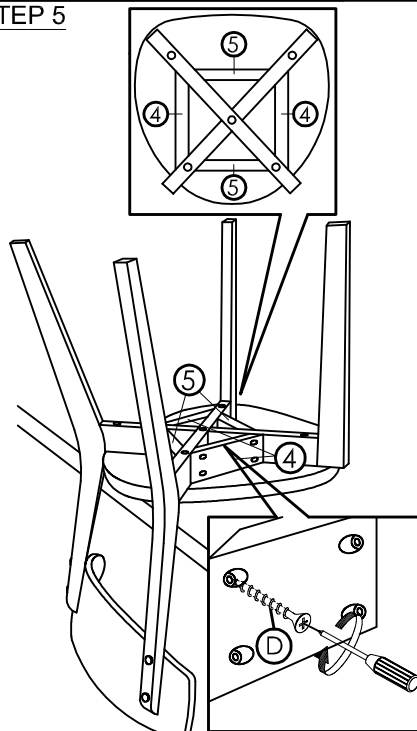

STEP 6

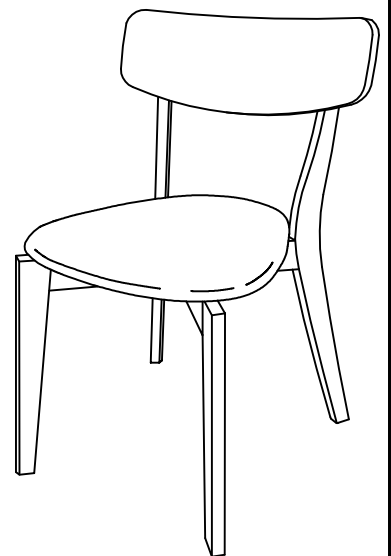

COMPLETED CHAIR ASSEMBLY.